

TECHNICAL MANUAL

OPERATOR'S, UNIT,  
DIRECT SUPPORT AND  
GENERAL SUPPORT  
MAINTENANCE MANUAL  
FOR

**SHELTER, ELECTRICAL  
EQUIPMENT S-280B/G  
(NSN 5411-00-117-2868)**

**S-280B/G (SHIELDED)  
(NSN 5411-00-001-4093)**

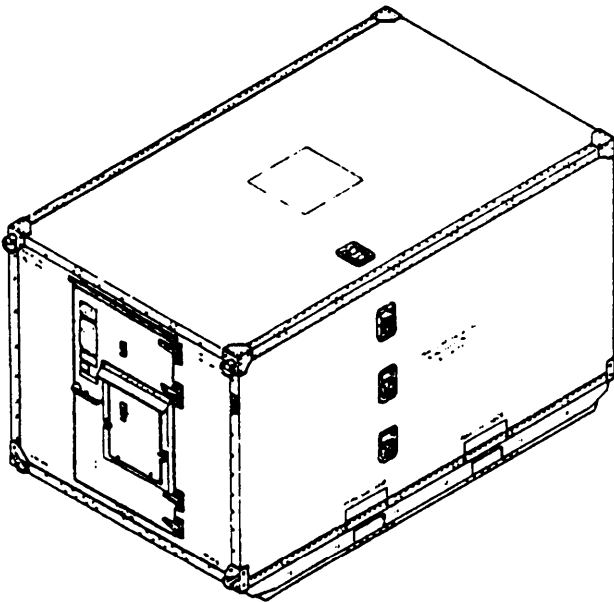

INTRODUCTION 1-1

OPERATOR PMCS 2-1

UNIT MAINTENANCE  
INSTRUCTIONS 3-1

DIRECT SUPPORT  
MAINTENANCE INSTRUCTIONS 4-1

GENERAL SUPPORT  
MAINTENANCE INSTRUCTIONS 5-1

REFERENCES A-1

MAINTENANCE ALLOCATION CHART B-1

COMPONENTS OF END ITEM AND BASIC  
ISSUE ITEMS LISTS C-1

EXPENDABLE/DURABLE SUPPLIES AND  
MATERIALS LIST D-1

DISTRIBUTION STATEMENT A: Approved for public release; distribution is unlimited.

**HEADQUARTERS, DEPARTMENT OF THE ARMY  
30 SEPTEMBER 1993**

**WARNING**

Drilling creates metal chips which may enter eyes and cause serious injury. Eye protection is required.

Adhesives and solvents are flammable and toxic. Keep away from heat and open flames. Use in a well-ventilated area. Avoid skin and eye contact and breathing of vapors. Use protective goggles and gloves. Use in accordance with manufacturer's instructions.

**Operator's, Unit, Direct Support and General Support  
Maintenance Manual  
for  
SHELTER, ELECTRICAL EQUIPMENT  
S-280B/G (NSN 5411-00-117-2868)  
S-280 B/G (Shielded) (NSN 5411-00-001-4093)**

**REPORTING ERRORS AND RECOMMENDING IMPROVEMENTS**

You can help improve this manual. If you find any mistakes or if you know of a way to improve the procedures, please let us know. Mail your letter or DA Form 2028 (Recommended Changes to Publications and Blank Forms), or DA Form 2028-2 located in the back of this manual directly to: Commander, US Army Aviation and Troop Command, ATTN: AMSAT-I-MP, 4300 Goodfellow Blvd., St. Louis, MO 63120-1798. A reply will be furnished directly to you.

DISTRIBUTION STATEMENT A: Approved for public release; distribution is unlimited.

TABLE OF CONTENTS

	Page
CHAPTER I	
<u>INTRODUCTION</u> .....	1-1
Section I	
General Information .....	1-1
Section II	
Equipment Description .....	1-2
CHAPTER 2	
<u>OPERATING INSTRUCTIONS</u> .....	2-1
Section I	
<u>Operator Preventive Maintenance Checks and Services (PMCS)</u> .....	2-1
Section II	
Operation Under Usual Conditions .....	2-4
Section III	
Operation Under Unusual Conditions .....	2-6
CHAPTER 3	
<u>UNIT MAINTENANCE INSTRUCTIONS</u> .....	3-1
Section I	
Lubrication .....	3-1
Section II	
Repair Parts, Special Tools, TMDE and Support Equipment .....	3-1
Section III	
Service Upon Receipt .....	3-1
Section IV	
Troubleshooting .....	3-4
Section V	
Unit Maintenance Procedures .....	3-7
Section VI	
Preparation for Shipment and Storage .....	3-35

TABLE OF CONTENTS (cont)

	Page
CHAPTER 4	4-1
<hr/>	
<u>DIRECT SUPPORT MAINTENANCE INSTRUCTIONS</u> .....	4-1
Section I	4-1
Repair Parts, Special Tools, TMDE and Support Equipment .....	
Section II	4-1
Troubleshooting .....	
Section III	4-3
Direct Support Maintenance Procedures .....	
CHAPTER 5	5-1
<hr/>	
<u>GENERAL SUPPORT MAINTENANCE INSTRUCTIONS</u> .....	5-1
Section I	5-1
Repair Parts, Special Tools, TMDE and Support Equipment .....	
Section II	5-1
General Support Maintenance Procedures .....	
APPENDIX A	A-1
<hr/>	
<u>REFERENCES</u> .....	A-1
APPENDIX B	B-1
<hr/>	
<u>MAINTENANCE ALLOCATION</u> .....	B-1
APPENDIX C	C-1
<hr/>	
<u>COMPONENTS OF END ITEM AND BASIC ISSUE ITEMS</u> .....	C-1
APPENDIX D	D-1
<hr/>	
<u>EXPENDABLE AND DURABLE SUPPLIES AND MATERIALS LIST</u> .....	D-1
INDEX	I-1
<hr/>	

LIST OF ILLUSTRATIONS

Figure Number	Title	Page
1-1	Major Shelter Components . . . . .	1-3
1-2	Shelter Marking . . . . .	1-4
2-1	Instruction and Warning Plates . . . . .	2-5
3-1	Lifting and Loading Shelter . . . . .	3-3
3-2	Securing Shelter on 21/2 Ton Truck . . . . .	3-5
3-3	Rivet Types . . . . .	3-9
3-4	Installing Blind Rivets . . . . .	3-11
3-5	Removing Blind Rivets . . . . .	3-13
3-6	Rivnuts (Threaded Inserts) . . . . .	3-13
3-7	Installing Rivnuts . . . . .	3-14
3-8	Removing Rivnuts . . . . .	3-16
3-9	Door Brace Assembly Removal and Disassembly . . . . .	3-19
3-10	Door Brace Assembly Reassembly and installation . . . . .	3-20
3-11	Emergency Exit panel Assembly Replacement . . . . .	3-22
3-12	T-Latch and Holder Replacement . . . . .	3-23
3-13	Door Latch Assembly Removal and Disassembly . . . . .	3-25
3-14	Door Latch Assembly Reassembly and Installation . . . . .	3-27
3-15	Air inlet Filter Replacement . . . . .	3-30
3-16	Recessed Step Pan Assembly Replacement . . . . .	3-31
3-17	D-Ring Assembly Replacement . . . . .	3-33
3-18	Drain Plug and EMI Washer Replacement . . . . .	3-34
4-1	Drip Mold Replacement . . . . .	4-4
4-2	Data Plate Replacement . . . . .	4-5
4-3	Door Stop Angle Replacement . . . . .	4-6
4-4	Weather Gasket Replacement . . . . .	4-10
4-5	Drip Cap Replacement . . . . .	4-11
4-6	Emergency Exit Latch, Strike and Stud Plate Assembly Replacement . . . . .	4-13
4-7	intake Louver Assembly and RFI/EMI Filter Replacement . . . . .	4-15
4-8	Door Knob Assembly Replacement . . . . .	4-17
4-9	Door Hinge Assembly Replacement . . . . .	4-19
4-10	Panel Repair . . . . .	4-25
5-1	Door Assembly Replacement . . . . .	5-3
5-2	Towing Eye Assembly Repair and Replacement . . . . .	5-5
5-3	Lifting Eye Assembly Repair and Replacement . . . . .	5-7
5-4	RFI/EMI Shielding Gasket Replacement . . . . .	5-9
5-5	Panel Repair . . . . .	5-13
5-6	Skid Assembly and Mounting Bracket Replacement . . . . .	5-15

**LIST OF TABLES**

Table Number	Title	Page
2-1	Operator Preventive Maintenance Checks and Services . . . . .	2-2
3-1	Troubleshooting . . . . .	3-6
3-2	Blind Rivets . . . . .	3-9
3-3	Rivnuts . . . . .	3-14
4-1	Troubleshooting . . . . .	4-2

**HOW TO USE THIS MANUAL**

This manual is designed to help you keep your shelter in good operating condition. The front cover index is provided for quick reference to important information. There is also an index located in the final pages for use in locating specific items of information.

Warning pages are located in the front of this manual. You should learn the warnings before performing any maintenance on the equipment.

Paragraphs in this manual are numbered by chapter and order of appearance within a chapter. A subject index appears at the beginning of each chapter listing sections that are included in that chapter. A more specific subject index is located at the beginning of each section to help you find the exact paragraph you are looking for.

# CHAPTER 1

## INTRODUCTION

Subject	Section	Page
General Information . . . . .	I	1-1
Equipment Description . . . . .	II	1-2

### Section I. GENERAL INFORMATION

Subject	Para	Page
Scope . . . . .	1-1	1-1
Maintenance Forms and Records . . . . .	1-2	1-1
Reporting Equipment Improvement Recommendations . . . . .	1-3	1-1
Destruction of Army Materiel to Prevent Enemy Use . . . . .	1-4	1-1
Preparation for Shipment and Storage . . . . .	1-5	1-2
List of Abbreviations . . . . .	1-6	1-2

#### 1-1. **Scope.**

*a. Type of Manual.* This technical manual includes operator, unit, direct support and general support maintenance procedures for the basic S-280B/G and S-280B/G Shielded shelters. Additional maintenance data relevant to a configured shelter can be found in the applicable end item technical manual.

*b. Equipment Name and Model Number.* This technical manual covers electrical Equipment Shelters S-280B/G. Some configurations of the S-280B/G shelter are equipped with radio frequency/electromagnetic interference shielding.

*c. Purpose of Equipment.* The S-280B/G and S-280B/G Shielded are lightweight transportable shelters designed for use with the Area Type Communication Systems and other communication systems.

**1-2. Maintenance Forms and Records.** Department of the Army forms and procedures used for equipment maintenance will be those prescribed by DA Pam 738-750, The Army Maintenance Management System (TAMMS).

**1-3. Reporting Equipment Improvement Recommendations (EIRs).** If your Shelter needs improvement, let us know. Send us an EIR. You, the user, are the only one who can tell us what you don't like about your equipment. Let us know why you don't like the design or performance. Put it on an SF 368 (Product Quality Deficiency Report). Mail it to: Commander, S Army Aviation and Troop Command, ATTN: AMSAT-I-MDO, 4300 Goodfellow Blvd., ST. Louis, MO 63120-1798. We'll send you a reply.

**1-4. Destruction of Army Materiel to Prevent Enemy Use.** Destruction of Army equipment to prevent enemy use shall be in accordance with TM 750-244-3.

1-5. **Preparation for Shipment and Storage.** Refer to paragraphs 3-21 through 3-24 for shipment and storage preparation data.

1-6. **List of Abbreviations.**

RFI	Radio Frequency Interference
EMI	Electromagnetic Interference
TMDE	Test, Measurement and Diagnostic Equipment
CARC	Chemical Agent Resistive Coating

Section II. EQUIPMENT DESCRIPTION

Subject	Para	Page
Equipment Characteristics, Capabilities and Features . . . . .	1-7	1-2
Location and Description of Major Components . . . . .	1-8	1-2
Differences Between Models . . . . .	1-9	1-3
Equipment Data . . . . .	1-10	1-3
Shelter Marking . . . . .	1-11	1-3
Safety, Care and Handling . . . . .	1-12	1-3

1-7. **Equipment Characteristics, Capabilities and Features.** The S-280B/G and S-280B/G Shielded shelters are lightweight, relocatable shelters used to transport and house ground communications equipment. The foam and beam shelter construction consists of aluminum face sheets enclosing a polyurethane foam composition core. The shielded shelters are equipped with radio frequency/electromagnetic interference (RFI/EMI) shielding to protect the electronic equipment contained inside. The shield is a continuous metallic surface which includes the shelter panel inner face sheets and conductive materials which maintain continuity around joints, door openings and other possible sources of radiation leakage. Shielded shelters also have an RFI/EMI filter inside the emergency exit panel. Shielded shelters can be identified by the metallic door gasket which mates with another conductive surface on the doorjamb. The shelter is designed for outdoor use in all weather conditions.

1-8. **Location and Description of Major Components.** (figure 1-1)

ITEM	DESCRIPTION
1. Door Assembly	Provides access to equipment contained in shelter.
2. Emergency exit panel	Contains air vent and filter and serves as an emergency exit. In shielded shelters, inner door also houses RFI/EMI filter.
3. Lifting eye assemblies	Provide hookup points for sling assembly when lifting shelter and when securing shelter onto truck.
4. Towing eye assemblies	Provide hookup points for guide rope when guiding sling-lifted shelter into position.
5. Roof Access Steps	Allow access to roof.



1-9. **Differences Between Models.** The S-280B/G Shielded shelter (NSN 5411-00-001-4093) differs from the S-280B/G (NSN 5411-00-117-2868) only in its radio frequency/electromagnetic suppression capabilities. Components of RFI/EMI shielding are described in paragraph 1-7.

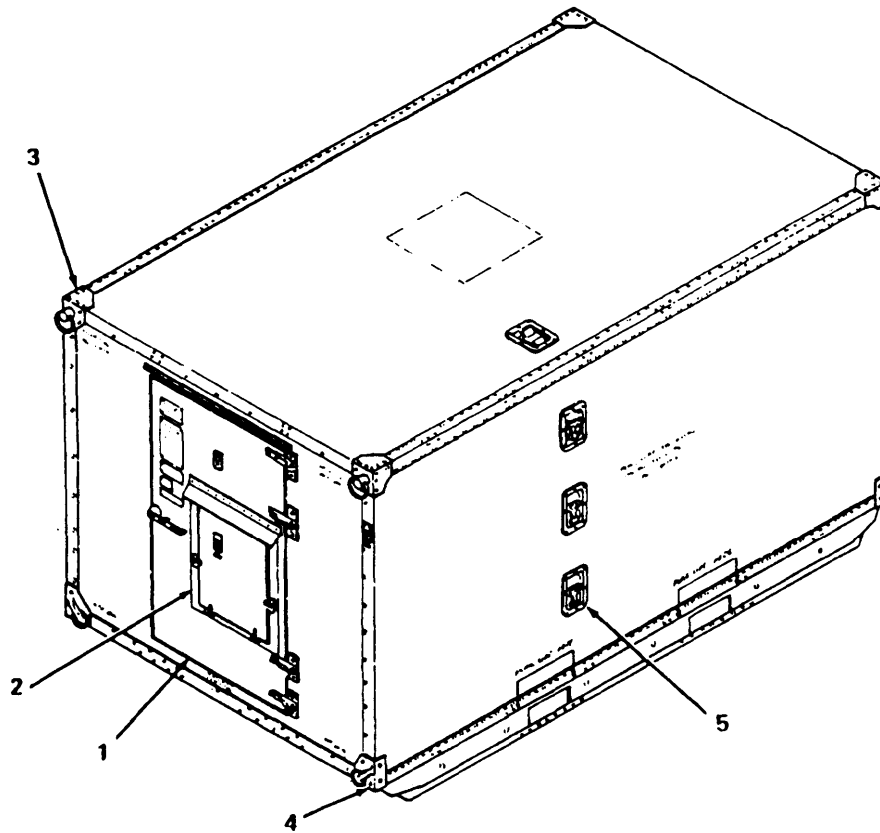

4753-002

Figure 1-1. Major Shelter Components.

1-10. **Equipment Data.**

Height	83.325 in. (21 1.65 cm)
Width	87 in. (220.98 cm)
Length	147 in. (373.68 cm)
Gross weight	1380 lb (627 kg)
Cubage	617 ft <sup>3</sup> (17.47 m <sup>3</sup> )
Load on skids	0.9 psi

1-11. **Shelter Marking.** Shelter markings are shown in figure 1-2. Lettering is stenciled or silkscreened in accordance with MIL-M-1321 GR II. The color used is black, MIL-C-46168.

1-12. **Safety, Care and Handling.** Throughout this manual are warnings, cautions and notes designed to protect personnel and equipment when handling the shelter. Learn the warnings on the warning page before attempting to perform maintenance on the shelter, and observe all warnings, cautions and notes as you come upon them in the text.

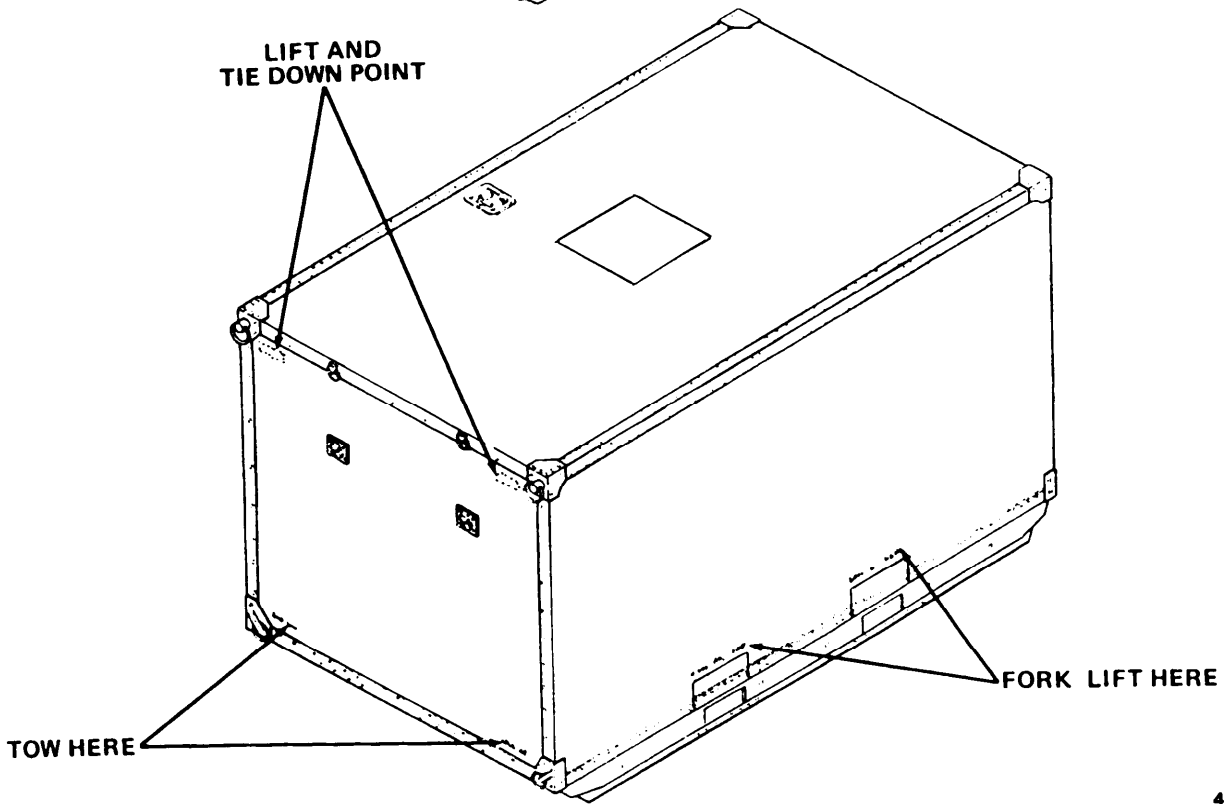
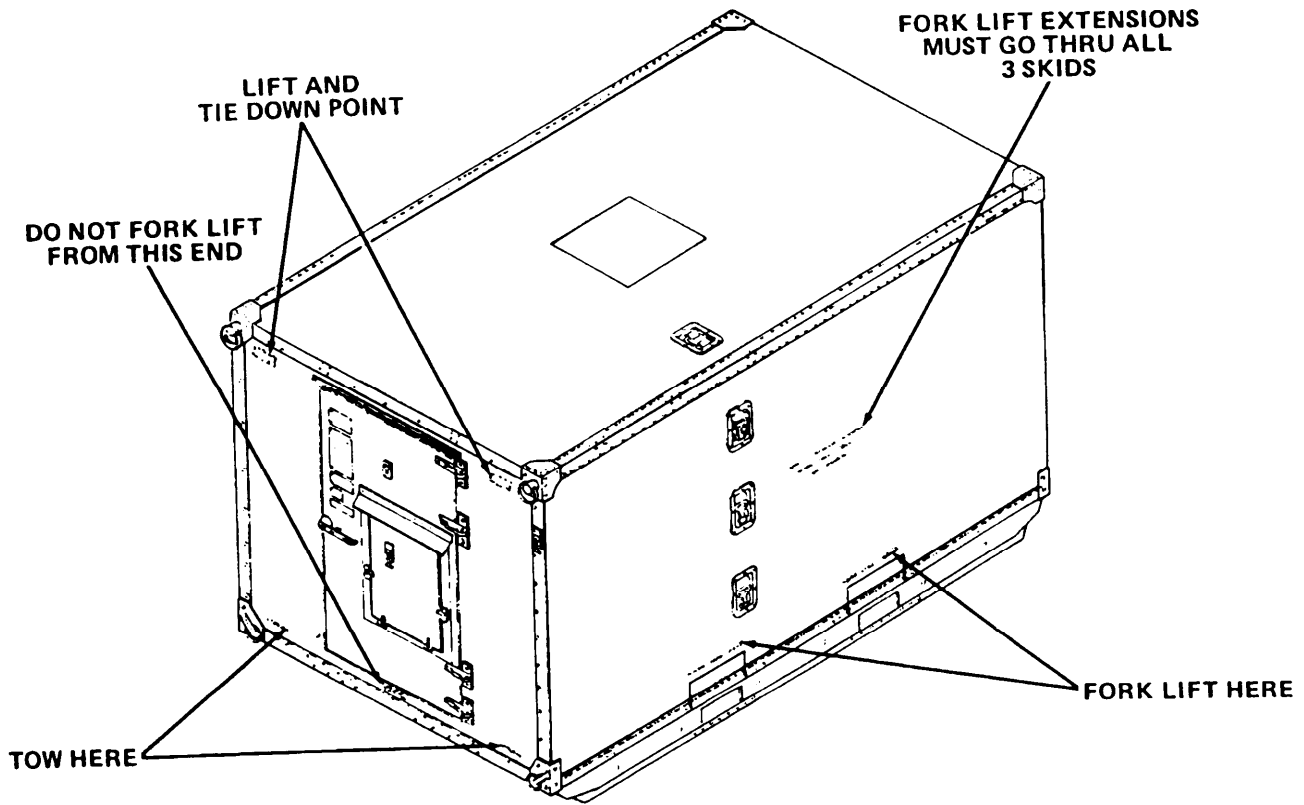

4753-003

Figure 1-2. Shelter Marking.

## CHAPTER 2

### OPERATING INSTRUCTIONS

Subject	Section	Page
Operator Preventive Maintenance Checks and Services (PMCS) . . . . .	I	2-1
Operation Under Usual Conditions . . . . .	II	2-4
Operation Under Unusual Conditions . . . . .	III	2-6

#### **Section I. OPERATOR PREVENTIVE MAINTENANCE CHECKS AND SERVICES (PMCS)**

Subject	Para	Page
General . . . . .	2-1	2-1
Explanation of Columns . . . . .	2-2	2-1

2-1. **General.** Your Preventive Maintenance Checks and Services table lists the inspections required to keep your equipment in good operating condition.

*a. Before You Operate.* Always keep in mind the CAUTIONS and WARNINGS. Perform your before (B) PMCS.

*b. While You Operate.* Always keep in mind the CAUTIONS and WARNINGS. Perform your during (D) PMCS.

*c. After You Operate.* Be sure to perform your after (A) PMCS.

*d. Weekly.* (Perform your weekly (W) PMCS.

*e. Once Each Month.* Perform your monthly (M) PMCS.

*f. If Your Equipment Fails to Operate.* If your equipment does not perform as required, notify higher level of maintenance. Report any malfunctions or failures on the proper DA Form 2404 or refer to DA Pam 738-750.

#### **2-2. Explanation of Columns.**

*a. Item Number.* The item number is to be used as a source number for the TM number column on DA Form 2404, Equipment Inspection and Maintenance Worksheet, when recording PMCS results.

*b. Interval.* The interval column of your PMCS table tells you when to do a certain check or service.

*c. Item To Be Inspected.* This column lists the components that require inspection.

*d. Procedures.* This column lists the faults to check for and procedures to follow.

*e. Equipment is Not Ready/Available If.* This column tells you when and why your equipment cannot be used.

2-2. Explanation of Columns (cont).

NOTE

Perform your weekly as well as before checks if your are the assigned operator and have not operated the equipment since the last weekly check, or if you are operating the equipment for the first time.

**Table 2-1. Operator Preventive Maintenance Checks and Services.**

NOTE

Within the designated interval, these checks are to be performed in the order listed.

B – Before                      D – During                      A–After                      W – Weekly                      M – Monthly

Item No.	Interval					Item to be Inspected	Procedures Check for and have repaired or adjusted as necessary	Item is Not Ready/ Available If:
	B	D	A	W	M			
1	•			•		Door Handle	Make sure handle operates smoothly without binding or jamming.	Door cannot be opened or cannot be closed securely.
2	•			•		Emergency Exit Panel	a. Make sure cover can be held in the open position using T-latch.  b. Make sure weather gasket is in good condition.	
3	•			•		Door Brace Assembly	Make sure door brace assembly pivot points rotate easily. Check for loose or missing hardware.	
4	•			•		Door Assembly	a. Make sure door opens and closes smoothly without binding. Check hinges for rust, loose or missing hardware. Lubricate hinges.  b. Make sure drip cap and drip molding are intact.  c. Make sure air filters and louvers are not missing or blocked.	

**Table 2-1. Operator Preventive Maintenance Checks and Services (cont).**

B – Before

D – During

A – After

W – Weekly

M – Monthly

Item No.	Interval					Item to be Inspected	Procedures Check for and have repaired or adjusted as necessary	Item is Not Ready/ Available If:
	B	D	A	W	M			
4						Door Assembly (cont)	d. Check door surfaces for punctures. e. Make sure weather gaskets are in good condition.	
5	•				•	Lifting and Towing Eye Assemblies	a. Inspect for excessive wear. b. Inspect for rust, loose or missing hardware. c. Make sure rings and pins rotate freely.	
6					•	Roof Access Steps	a. Make sure steps stay in up or down position as required. b. Check for loose or missing hardware.	
7					•	Roof Handle	Check for loose or missing hardware.	
8		•				Drain Plug	Make sure drain plug is in place.	Drain plug is missing (shielded shelters).
9		•			•	RFI/EMI Components (S-280B/G Shielded)	a. Inspect metal door gaskets. b. Inspect filter. c. Check for presence of drain plug washer, keeper shims and hinge shims.	a. One or both gaskets are missing or damaged. b. Filter is damaged or missing. c. A washer or shim is missing.
10	•				•	Wall, Floor and Ceiling Panels	Inspect for punctures and delamination.	Punctures are present.

**Table 2-1. Operator Preventive Maintenance Checks and Services (cont).**

Item No.	Interval					Item to be Inspected	Procedures Check for and have repaired or adjusted as necessary	Item is Not Ready/ Available If:
	B	D	A	W	M			
11	•					Skids and Mounting Brackets	Make sure skids and mounting brackets are securely mounted to shelter and are undamaged.	

**Section II. OPERATION UNDER USUAL CONDITIONS**

Subject	Para	Page
Assembly and Preparation for Use . . . . .	2-3	2-4
Initial Adjustments . . . . .	2-4	2-4
Operator Procedure . . . . .	2-5	2-4
preparation for Movement . . . . .	2-6	2-4
Instruction and Warning Plates . . . . .	2-7	2-5

2-3. **Assembly and Preparation for Use.** There are no assembly or preparation procedures that must be performed before using the basic shelter. For all assembly and preparation procedures applicable to a configured shelter, refer to the end item technical manual.

2-4. **Initial Adjustments.** The shelter itself requires no adjusting. However, the operator must make certain the shelter is positioned so that the doors can be fully opened and closed and that any external equipment required for operation of the shelter-contained equipment can be properly installed. Refer to the end item technical manual for additional procedures applicable to the configured shelter.

2-5. **Operating Procedures.** There are no operating procedures applicable to the basic shelter. Refer to the end item technical manual for operating procedures applicable to the configured shelter.

2-6. **Preparation for Movement.** Before moving the shelter, make sure the doors are closed and padlocked. If the shelter is being moved by truck, make sure the shelter is properly tied down and blocked to prevent movement. Refer to paragraph 3-5 for instructions for securing the shelter on a truck. If the shelter must be loaded onto a truck for movement, refer to paragraph 3-5 for lifting and loading instructions. Refer to the end item technical manual for additional preparation instructions applicable to the configured shelter.

2-7. **Instruction Plates.** (figure 2-1)

ITEM	CONTENT
1. Airborne Instruction Plate	Open cover before airlift Keep vent cover open when shelter is occupied Keep drain plug loose during air and rail transport
2. Paint Instruction Plate	The surfaces of this shelter have been painted with CARC For touch-up Exterior – Use only lusterless green 383 polyurethane IAW MIL-C-46168 Interior – Use only epoxy polyamide IAW MIL-C-22750
3. Secondary Exit Data Plate	Secondary exit Remove 4 hand knobs Lift out exit panel
4. Door Closing Instruction Plate	Push catch to release door stop brace.

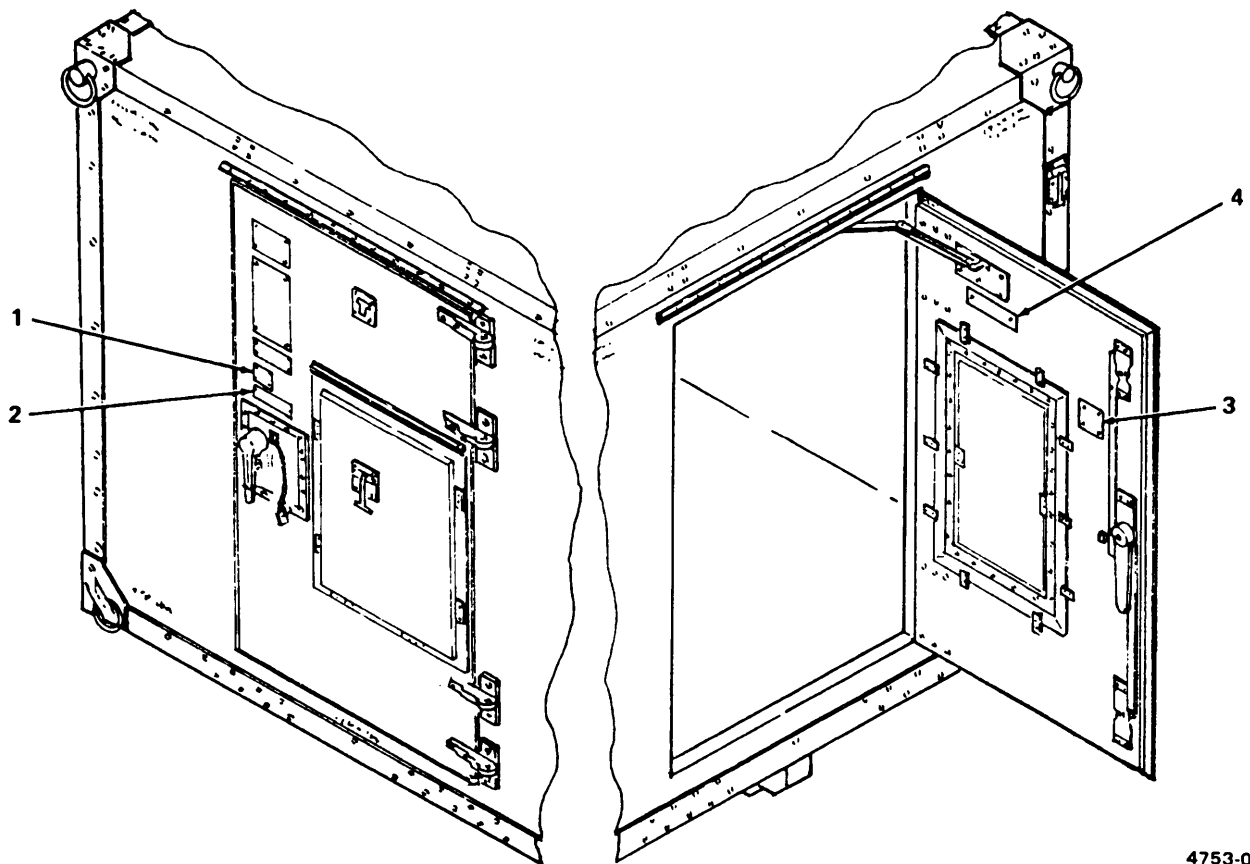

4753-004

*Figure 2-1. Instruction and Warning Plates.*

**Section III. OPERATION UNDER UNUSUAL CONDITIONS**

Subject	Para	Page
Operation in Unusual Weather .....	2-8	2-6
Emergency Procedures .....	2-9	2-6

**2-8. Operation In Unusual Weather.** The shelters are designed for use in all weather. However, shelters located at coastal sites and subject to salt air deterioration, or areas subject to wind-driven sand or coral dust shall be inspected by site personnel at least once every week to assure timely determination of maintenance and repair needs. Additional requirements for operation in unusual weather can be found in the end item technical manual.

**2-9. Emergency Procedures.** Any damage to the shelter walls or ceiling must be patched immediately to prevent water intrusion. In an emergency, any kind of tape or water-resistant materials may be used to cover a puncture or a large hole. Temporary patches must be replaced with permanent patches as soon as possible. In a shielded shelter, temporary patches must be replaced as soon as possible to restore RFI/EMI suppression.



## CHAPTER 3

### UNIT MAINTENANCE INSTRUCTIONS

Subject	Section	Page
Lubrication . . . . .	I	3-1
Repair Parts, Special Tools, TMDE and Support Equipment . . . . .	II	3-1
Service Upon Receipt . . . . .	III	3-1
Troubleshooting . . . . .	IV	3-4
Unit Maintenance Procedures . . . . .	V	3-7
Preparation for Shipment and Storage . . . . .	VI	3-35

#### Section I. LUBRICATION

3-1. **Lubrication Instructions.** There is no scheduled lubrication. However, lubricate door and emergency exit panel cover hinges, latches and locking mechanisms, door brace assembly, roof access steps and lifting and towing eye assemblies to prevent rust and corrosion. Check these parts frequently to be sure they are adequately lubricated. Lubricate with Solid Film Lubrican, MIL-L-23398. There is no scheduled lubrication for the shelter. Lubricate as necessary to prevent rust corrosion and wear.

#### Section II. REPAIR PARTS, SPECIAL TOOLS, TMDE AND SUPPORT EQUIPMENT

Subject	Para	Page
Common Tools . . . . .	3-2	3-1
Special Tools, TMDE and Support Equipment . . . . .	3-3	3-1
Repair Parts . . . . .	3-4	3-1

3-2. **Common Tools.** A complete list of common tools and tool kits is given in Section III of Appendix B, Maintenance Allocation.

3-3. **Special Tools, TMDE and Support Equipment.** There are no special tools or equipment needed to maintain the shelters.

3-4. **Repair Parts.** Repair parts for unit maintenance of the shelters are listed and illustrated in TM 10-541 1-206-24P.

#### Section III. SERVICE UPON RECEIPT

Subject	Para	Page
Service Upon Receipt of Materiel . . . . .	3-5	3-2
Site Requirements . . . . .	3-6	3-4

3-5. **Service Upon Receipt of Materiel.** Inspect the shelter for damage incurred during shipment. If the shelter has been damaged, report the damage on SF 364, Report of Item Discrepancy. If the drain plug has been loosened for shipment, tighten it. If the shelter is crated or pallet-mounted, refer to the end item technical manual for unpacking instructions. If it is necessary for the shelter to be loaded onto a truck or transferred from one truck to another, lift, load and secure the shelter as follows:

**WARNING**

If shelter panel is punctured during loading or securing, repair puncture as soon as possible to prevent moisture from seeping into panels, and to restore RFI/EMI shielding in shelters having this requirement. Failure to do so may result in exposure of personnel to radiation.

a. *Lifting Shelter.* (figure 3-1)

**CAUTION**

On "Craig Round Corner" shelters, do not attempt to lift shelter with sling assembly cables connected to tiedown eyes. Damage to equipment may result.

- (1) Attach sling assembly to all four lifting rings on shelter so that turnbuckle ends of cables are next to lifting rings. Be sure to use correct sling assembly (hold down assembly). (See Appendix C.)
- (2) Place sling assembly on top of shelter.
- (3) Connect four sling hooks at opposite ends of cables to sling assembly lifting ring.
- (4) Insert lifting hook of lifting device (crane or helicopter) into lifting ring.
- (5) Tie a 1/2-inch rope, at least 15 feet long, to each rear towing eye.

**CAUTION**

Do not jerk, bounce or jar shelter when lifting. Avoid swinging shelter from side to side. Do not attempt to butt or push shelter into place with a forklift. If shelter is crated, pallet-mounted or has forklift instructions stenciled on exterior, a forklift maybe used to move shelter in accordance with instructions.

- (6) Slowly lift shelter with crane or helicopter.

b. *Loading Shelter onto Truck.* (figure 3-1)

**WARNING**

To avoid injury to personnel and damage to shelter, only personnel actually engaged in loading operation should be permitted near truck, lifting device and shelter. To eliminate confusion, all instructions must come from loading crew supervisor.

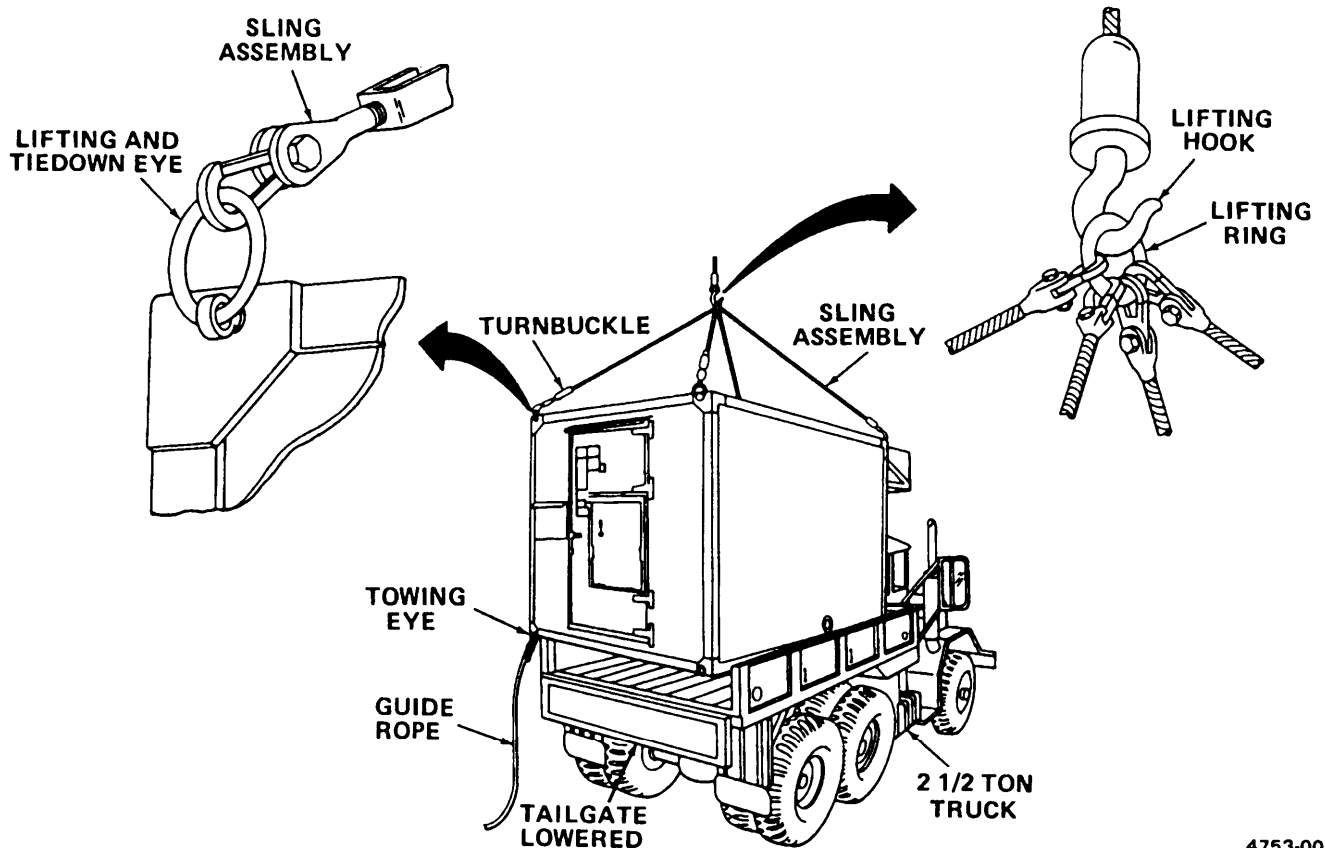

4753-005

*Figure 3-1. Lifting and Loading Shelter.*

**NOTE**

Some procedures require the addition of dunnage to truck bed or the attachment of tiedown eyes to truck before loading shelter onto truck. Refer to technical manual for type of truck being used.

- (1) Lower truck tailgate and make sure all tools and equipment have been removed from truck bed.
- (2) Position one person at free end of each rope to guide shelter into place.
- (3) Lift shelter to a position high enough to clear truck bed.
- (4) Back truck into position under shelter.

**WARNING**

To avoid injury to personnel, all personnel must remain clear of truck while shelter is being lowered into place.

- (5) With one person at each rope, guide shelter into position so that it is aligned above truck bed, and maintain that position while lowering shelter into place on truck bed.

### 3-5. Service Upon Receipt of Materiel (cont).

- (6) Remove lifting ring from lifting hook and separate lifting ring from sling hooks. Remove sling hooks from lifting eyes and remove ropes from rear towing eyes.

#### c. *Securing shelter on Truck.* (figure 3-2)

- (1) Install plate and eye bolt assemblies (part of sling assembly) on cargo bed siderails of truck as shown in figure 3-2.
- (2) Hook ends of four sling assemblies to tiedown eyes at each top corner of shelter, using hooks at furthest end of cables from turnbuckles.
- (3) Hook sling hooks at opposite end of cables to appropriate eye bolts on truck. Make sure sling hooks point away from shelter.
- (4) Tighten all turnbuckles evenly by hand. Then turn each turnbuckle an additional one-half turn with a bar or rod inserted in turnbuckle slot.

#### CAUTION

Do not overtighten turnbuckles. Overtightening may tear lifting and tiedown eyes from shelter or damage eye assembly or shelter.

- (5) Insert appropriate size wooden blocks between shelter skids and sides of truck bed to prevent sideway movement strain on sling cables.
- (6) Insert appropriate size wooden blocks between shelter skids and cab wall of bed to protect cab wall and shelter towing eyes.
- (7) Raise and secure truck tailgate.

3-6. **Site Requirements.** Site requirements will depend on the requirements of the equipment contained in the shelter. Refer to the end item technical manual for siting instructions.

## Section IV. TROUBLESHOOTING

3-7. **Troubleshooting.** This section contains troubleshooting information for malfunctions which may develop in the shelters. Fault isolation is limited to those components which maybe repaired or replaced at the unit level. Table 3-1 lists the common malfunctions you may encounter during operation or maintenance of the shelter. Each malfunction is followed by a list of tests or inspections and corrective actions. These tests or inspections and corrective actions should be performed in the order listed. This manual cannot list all malfunctions that may occur. If you encounter a malfunction that is not listed or that cannot be corrected by the listed corrective actions, notify your supervisor.

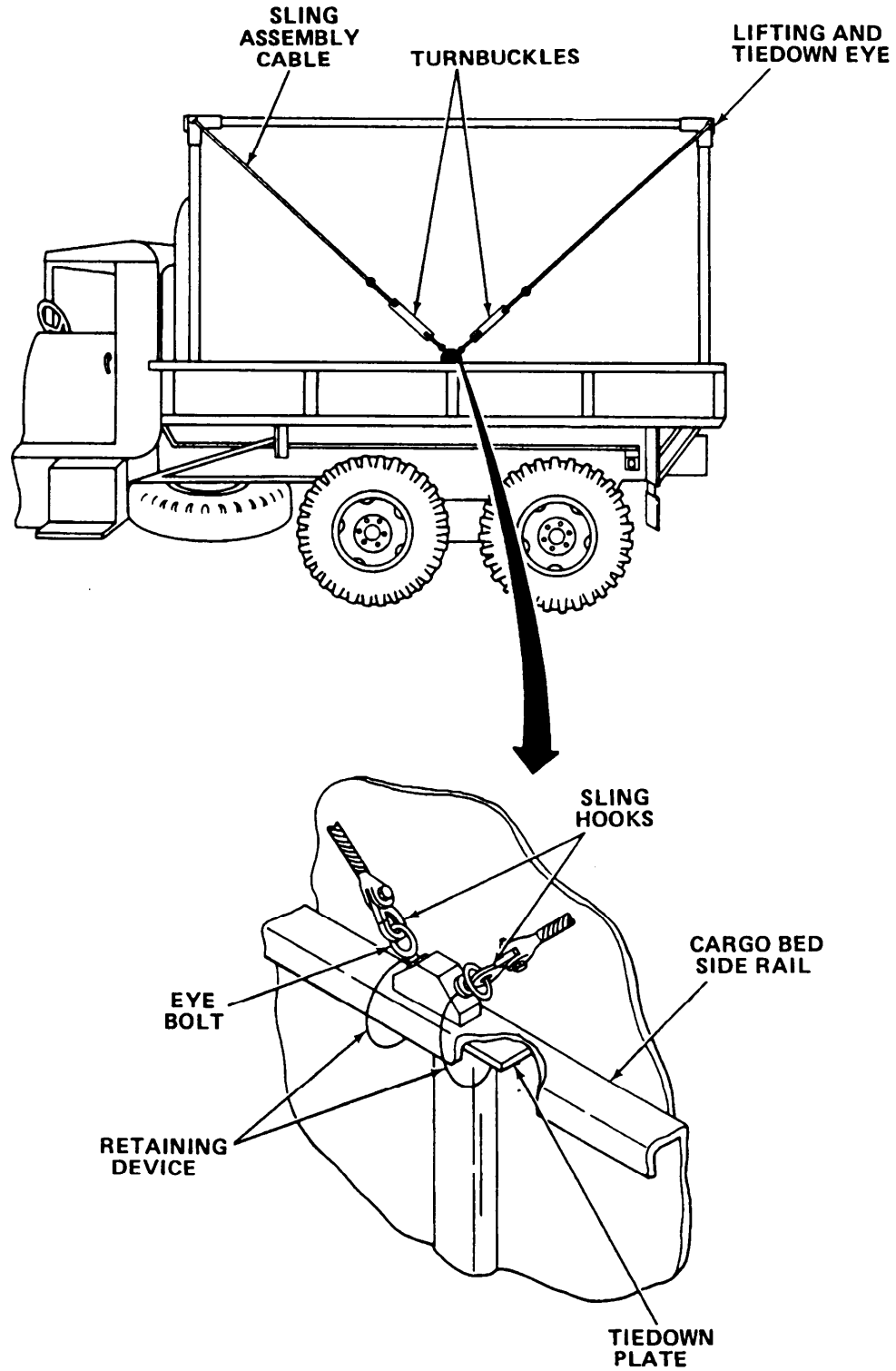

4753-006

Figure 3-2. Securing Shelter on 2 1/2 Ton Truck.

*Table 3-1. Troubleshooting*

---

MALFUNCTION	TEST OR INSPECTION	CORRECTIVE ACTION
-------------	--------------------	-------------------

---

1. DOOR DOES NOT OPEN OR CLOSE SMOOTHLY

Step 1. Inspect hinges for inadequate lubrication.

Lubricate as required (para 3-1).

Step 2. Notify higher level of maintenance.

2. DOOR DOES NOT STAY OPEN

Step 1. Check to see if door brace catch is missing or improperly installed.

Install catch (para 3-11).

Step 2. Check to see if door brace assembly is detached from door or door stop angle.

Replace missing hardware (para 3-11).

3. DOOR HANDLE IS JAMMED OR DOES NOT OPERATE SMOOTHLY

Step 1. Inspect components for inadequate lubrication.

Lubricate as required (para 3-1 ).

Step 2. Inspect door handle and latching mechanism for missing or damaged components.

Repair or replace components as required (para 3-15).

4. WATER IS GETTING INTO SHELTER

Step 1. Inspect shelter walls and ceiling for punctures.

Patch any holes (para 3-9.c).

Step 2. Check to see if roof access steps or d-ring hand holds have pulled away from shelter wall.

Apply sealer to gaps around step flange, or replace step (para 3-17) or d-ring (para 3-18).

Step 3. Notify higher level of maintenance.

**Table 3-1. Troubleshooting (cont).**

MALFUNCTION	TEST OR INSPECTION	CORRECTIVE ACTION
5. THERE IS EVIDENCE OF RADIO FREQUENCY/ELECTROMAGNETIC INTERFERENCE (S-280 B/G SHIELDED)		
	Step 1. Check for missing latch keeper shims.	Install shims (para 3-15).
	Step 2. Check for missing drain plug washer.	Install washer (para 3-19).
	Step 3. Notify higher level of maintenance.	

**Section V. UNIT MAINTENANCE PROCEDURES**

Subject	Para	Page
General . . . . .	3-8	3-7
General Repair Procedures . . . . .	3-9	3-8
Touchup Painting . . . . .	3-10	3-17
Door Brace Assembly . . . . .	3-11	3-18
Door Assembly . . . . .	3-12	3-21
Emergency Exit Panel Assembly . . . . .	3-13	3-22
T-Latches and Holders . . . . .	3-14	3-23
Door Latch Assembly . . . . .	3-15	3-24
Air inlet Filter . . . . .	3-16	3-30
Recessed Step Pan Assemblies . . . . .	3-17	3-31
D-Ring Assemblies (Hand Holds) . . . . .	3-18	3-32
Drain Plug and EMI Washer . . . . .	3-19	3-34
RFI/EMI Components . . . . .	3-20	3-35

**3-8. General.** This section contains maintenance procedures which are the responsibility of unit maintenance, as authorized by the Maintenance Allocation Chart (appendix B). Since most shelters contain sensitive electronic equipment that cannot be easily removed, unit level maintenance and repair will primarily involve shelter exteriors or easily accessible interior areas, unless floors, ceilings or walls have evidence of water intrusion which can jeopardize operation of the equipment. The shelters shall be returned to the depot for repair if any of the following conditions exist:

- a. Panel damage spans a structural member.
- b. Replacement of an entire wall, ceiling or floor is required.
- c. Extensive equipment removal beyond the capability of the using unit is required.

3-8. **General (cont).**

d. Welding is required.

e. Damage to a structural member is severe enough to cause distortion of a wall, especially in edge or corner areas.

f. Lift, tow or tiedown fittings or corner castings are damaged severely enough to indicate possible damage to the underlying structural member.

**NOTE**

If nature of damage warrants it, print a caution notice using 4-inch high letters on all outside walls of the shelter as follows: CAUTION: DAMAGED SHELTER. DO NOT SLING LIFT.

Coat threads of all screws and bolts with sealer before installing. Fill rivet and rivnut holes with sealer before using.

Unless otherwise noted, procedures described apply to all three configurations of shelter covered by this technical manual.

Unless otherwise noted, all procedures can be performed by one person, using standard tools listed in Appendix B, Section III.

3-9. **General Repair Procedures.** The procedures described in this paragraph are general procedures that may be needed during repair or replacement of many of the shelter components. Wherever these general procedures apply, they are referenced at the appropriate point in the specific maintenance procedure paragraph.

a. *Blind Rivet Installation and Removal.* Blind rivets are used in locations where only one side of the area to be worked on is accessible. Blind pop rivets must be used in the shelter foam and beam panels, since the hammering required to install conventional rivets would damage the material. The types of rivets used in the shelter are shown in figure 3-3 and described in table 3-2. When installing floor patches, countersunk head rivets are preferred. Dome head rivets are an acceptable alternate. When installing interior wall patches, countersunk head rivets shall be used in any location in which dome head rivets will interfere with the proper installation of equipment. Closed end rivets shall be used for exterior repairs and floor repairs to prevent moisture and dirt from entering panels.



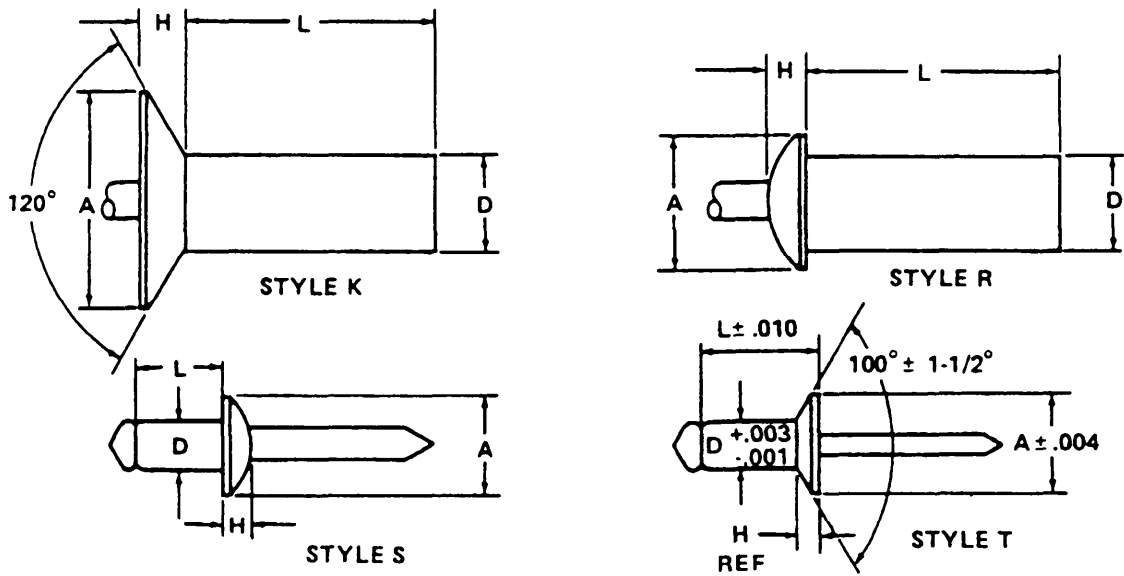

4753-007

Figure 3-3. Rivet Types.

Table 3-2. Blind Rivets.

Dash No.	Part No.	Style	Dim A	Dim H	Dim D	Dim L
SC-D-200131-29	AD62H	R	0.375	0.066	3/16	0.325
SC-D-200131-31	AD43H	R	0.236	0.036	1/8	0.357
SC-D-200131-35	AK64H	K	0.375	0.060	3/16	0.450
SC-D-200131-33	AD64H	R	0.375	0.066	3/16	0.450
SC-D-200131-30	AD42H	R	0.236	0.036	1/8	0.295
SC-D-200131-32	AD66H	R	0.375	0.066	3/16	0.575
SC-D-200131-26	AD45H	R	0.236	0.036	1/8	0.482
SC-D-200131-25	AD44H	R	0.236	0.036	1/8	0.420
SM-D-555530-7						
SC-D-200131-19	OSR-8D					
SC-D-200131-34	AD63H	R				
	MS20600AD4W-2	S	0.250	0.054	0.125	0.232
	NAS1398D6-5					
	NAS1399D8-5					
	NAS1399D4-4					
	NAS1399D4-3					
	NAS1398D4-4					
	NAS1739E4-3					
	MS20426AD6-8	K	0.353	0.070	0.187	0.500
	MS20470AD6-8	R	0.375	0.080	0.187	0.500
	MS20600AD6W-2	S	0.375	0.080	0.187	0.277
	MS20600AD6W-3	S	0.375	0.080	0.187	0.340
	MS20600AD6W-4	S	0.375	0.080	0.187	0.402
	MS20600AD6W-5	S	0.375	0.080	0.187	0.465

**Table 3-2. Blind Rivets (cont).**

Dash No.	Part No.	Style	Dim A	Dim H	Dim D	Dim L
SC-D-200131-4 SM-D-555530-5 SM-D-555530-6	MS20600AD8W-3	S	0.500	0.107	0.250	0.447
	MS20600AD8W-4	S	0.500	0.107	0.250	0.385
	MS20600AD4W-3	S	0.250	0.054	0.125	0.295
	OSR-8C					
	9SPB-RB-5					
	OSR-8B					
	MS20601AD6W-6	T	0.353	0.070	0.187	0.527
	MS20601AD6W-5	T	0.353	0.070	0.187	0.465
	MS20600AD4W-4	S	0.250	0.054	0.125	0.357
	MS20600AD8W-5	S	0.500	0.107	0.250	0.510
	MS20600AD8W-6	S	0.500	0.107	0.250	0.572
	MS20601AD6W-3	T	0.353	0.070	0.187	0.340
	MS20601AD6W-2	T	0.353	0.070	0.187	0.277
	MS20600AD6-6	S	0.375	0.080	0.187	1.200
	MS20601AD4W-3	T	0.225	0.042	0.125	0.750
	MS20601AD5W-3	T	0.286	0.055	0.156	0.808
	MS20601AD5W-2	T	0.286	0.055	0.156	0.620

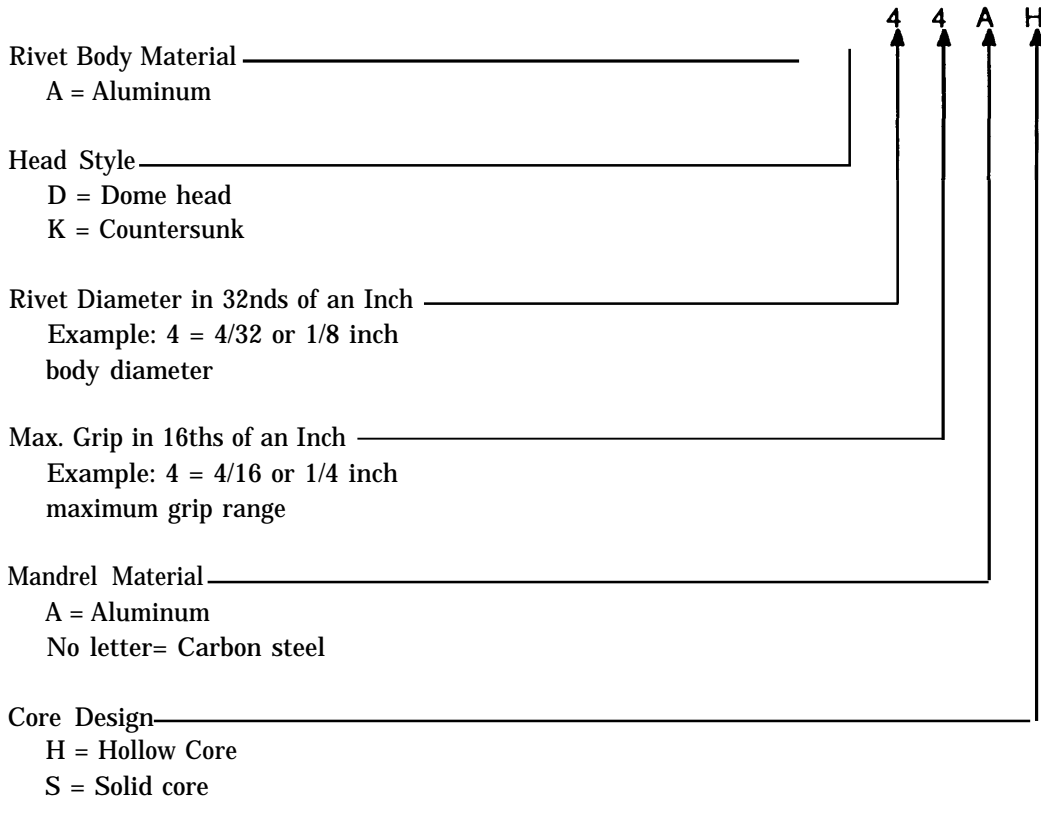

(1) *Installation.* (figure 3-4)

**NOTE**

When installing new rivet in same location as a rivet that has been removed, if diameter of hole in structure has been enlarged during removal of rivet, use next larger diameter rivet for replacement.

Clean rivets with solvent before installing.

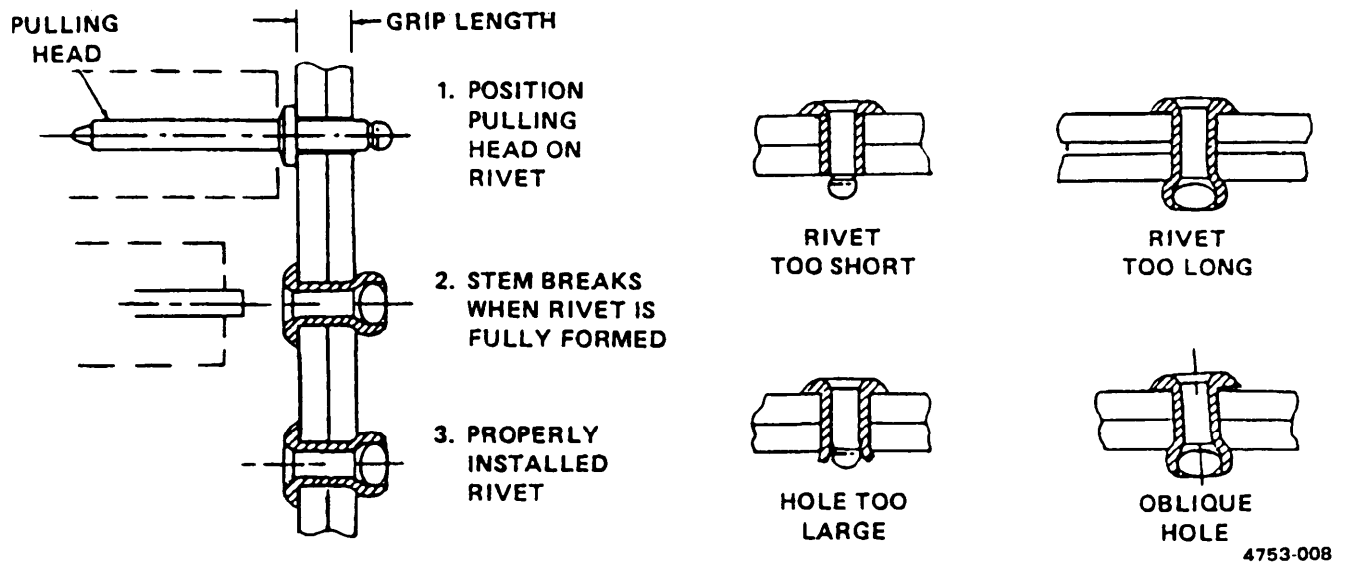

*Figure 3-4. Installing Blind Rivets.*

(a) Determine type, size and grip range of rivet to be used. Grip length equals combined thickness of materials being riveted together. Grip range of rivet must encompass grip length.

**WARNING**

Drilling creates metal chips which may enter eyes and cause serious injury. Eye protection is required.

**NOTE**

Drill hole size must match size of rivet being used.

Quantities of sheets maybe drilled at the same time when held together with sheet fasteners.

(b) Drill hole in structure.

(c) Remove all metal chips and remove burrs from drilled holes.

3-9. General Repair Procedures (cont).

- (d) If flush head rivet is being installed, countersink hole using a 100-degree machine countersink.

**NOTE**

Coat all rivets with sealer before installing.

- (e) Insert rivet in hole. Make sure sheets are held tightly together before upsetting or pulling rivet.
- (f) Select proper pulling head for rivet being installed and install pulling head on rivet gun.
- (g) Insert stem of rivet into pulling head.
- (h) With pulling head parallel to axis of rivet, upset rivet. Exert firm pressure but do not bend or buckle metal sheets. Stem will break off below rivet head surface. No trimming should be required.
- (i) Make sure riveted parts are not loose, rivet does not rotate and rivet head is seated tightly against riveted surface. If rivet is loose or improperly installed, remove it and install a new one.

(2) Removal. (figure 3-5)

**WARNING**

Drilling creates metal chips which may enter eyes and cause serious injury. Eye protection is required.

**NOTE**

When drilling through rivet head, be careful to avoid enlarging hole in structure. Keep drill perpendicular to material being drilled and do not exert excessive pressure on drill, Or replacement rivets will be too loose.

- (a) Drill through head of rivet only, using hole in rivet as a guide. Use proper drill size as follows:

Rivet size (in.)	Drill size
1/8	No. 31
5/32	No. 21
3/16	No. 12
1/4	1/4 inch

- (b) Using a pin punch, pry off rivet head.
- (c) Using pin punch, push out remainder of rivet shank. If shank will not easily push out, drill it out.

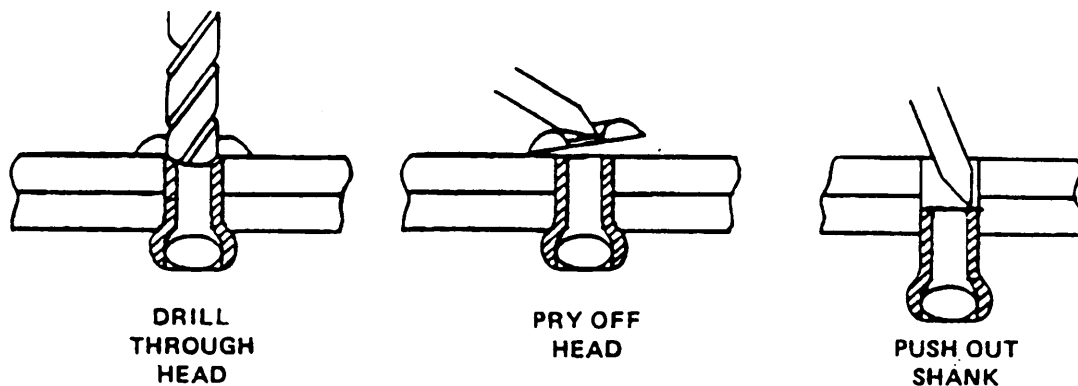

4753-009

Figure 3-5. Removing Blind Rivets.

*b. Rivnut Installation and Removal.* Rivnuts (threaded inserts) are tubular rivets with internal threads and are used throughout the shelter wherever blind threads are required. The types of rivnuts used in the shelter are shown in figure 3-6 and described in table 3-3. Flat head rivnuts may be used wherever head thickness will not interfere with installation of equipment. Countersunk head rivnuts are used for flush installation. Keyed rivnuts are used in locations which are subject to vibration and torque. Closed end rivnuts must be used for exterior repairs and floor repairs to keep moisture and dirt from entering panels. Open end rivnuts may be used in areas where sealing is not required.

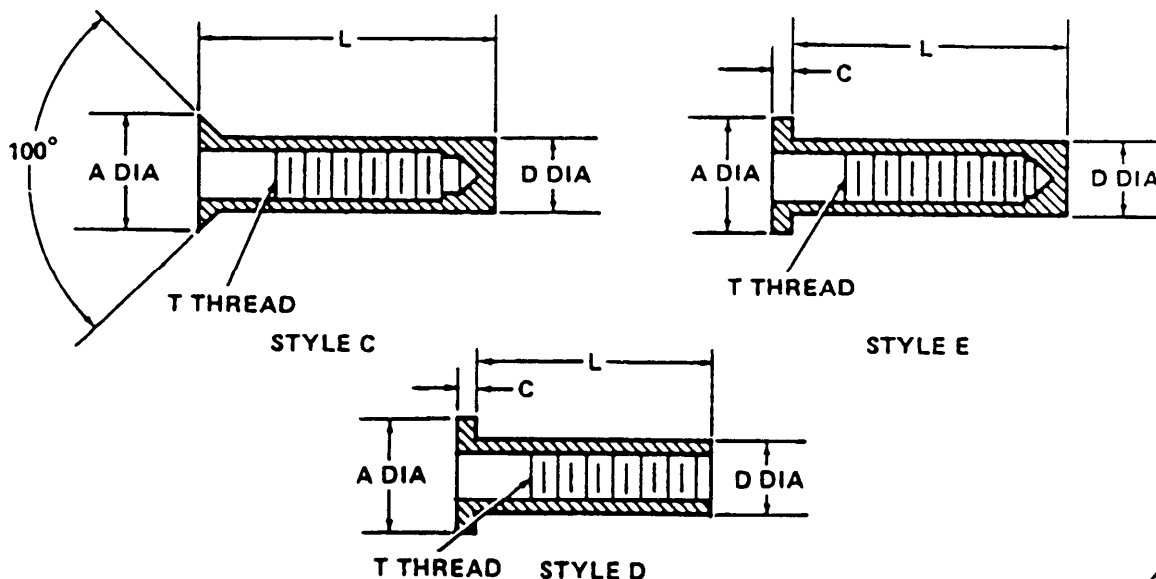

4753-010

Figure 3-6. Rivnuts (Threaded Inserts).

3-9. General Repair Procedures (cont).

Table 3-3. Rivnuts.

Dash No.	Part No.	Style	Dim A	Dim D	Dim L	T	Dim C	Grip Range
SM-D-555530-10	S25B211	C	0.529	0.332	1.062	1/4-20 UNC-3B		.151 -.211
SC-D-200131-7	S25B211	C	0.529	0.332	1.062	1/4-20 UNC-3B		.151 -.211
SM-D-555530-15	S31B500							
SC-D-200131-8	S31B500							
SC-D-200131-22	S25B140	E	0.475	0.332	1.000	1/4-20 UNC-3B	0.058	.080 -.140
SM-D-555530-20	S37B115							
SC-D-200131-9	S37B115							
SM-D-555530-21	S37B285							
SC-D-200131-10	S37B285							
SM-D-555530-24	S31B275							
SC-D-200131-11	S31B275							
SC-D-200131-20	S10B216							
SC-D-200131-21	S8B120							
SC-D-200131-24	S10B130							

(1) Installation. (figure 3-7)

NOTE

When installing new rivnut in same location as rivnut that has been removed, if diameter of hole in structure has been enlarged during removal, use next larger diameter rivnut for replacement.

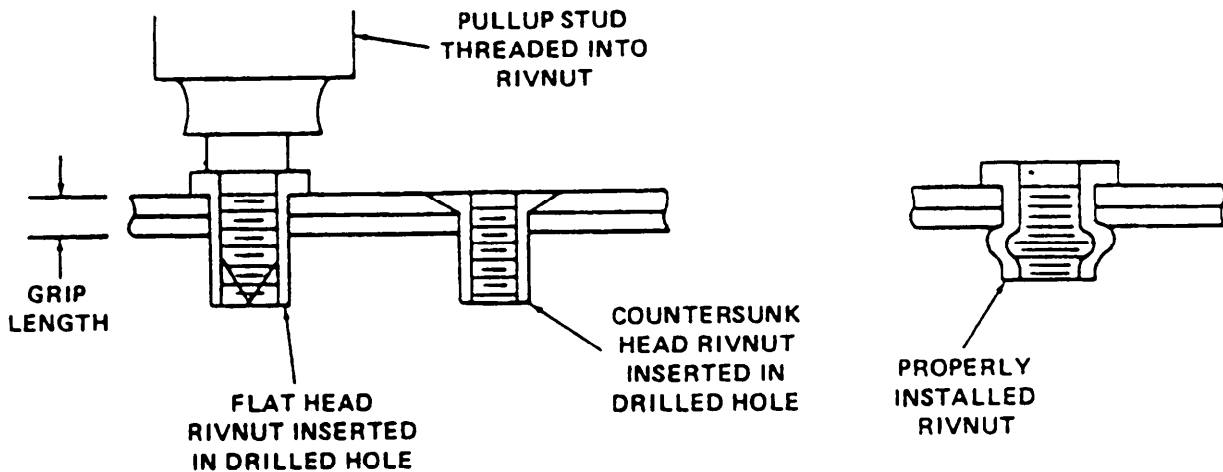

4753-011

Figure 3-7. Installing Rivnuts.

- (a) Determine thread size, grip range, style and material of rivnut to be used. Grip length equals combined thickness of materials being fastened together. Grip range of rivnuts must encompass grip length.

**WARNING**

Drilling creates metal chips which may enter eyes and cause serious injury. Eye protection is required.

**NOTE**

Drill hole size must match size of rivnut being installed. Quantities of sheets maybe drilled at the same time when held together with sheet fasteners.

- (b) Drill hole in structure.
- (c) Remove all metal chips and remove burrs from drilled holes.
- (d) If a countersunk head rivnut is being installed, countersink hole using a 100-degree machine countersink.

**NOTE**

Coat rivnut with sealer before installing.

- (e) Insert rivnut in hole. Make sure sheets are held tightly together before pulling.
  - (f) Thread stem of a pullup stud into rivnut.
  - (g) With pullup stud parallel to axis of rivnut, pull upon rivnut. Exert firm pressure but do not bend or buckle metal sheets.
  - (h) Make sure fastened parts are not loose, rivnut does not rotate and rivnut head is seated tightly against surface. Make sure rivnut threads are in good condition. If threads are damaged or rivnut is improperly installed, remove it and install a new one.
- (2) *Removal.* (figure 3-8)

**WARNING**

Drilling creates metal chips which may enter eyes and cause serious injury. Eye protection is required.

- (a) Drill through head of rivnut, using same size drill used to make original hole. Counterbore in rivnut will act as a drill guide.
- (b) Remove head of rivnut.

3-9. General Repair Procedures (cont).

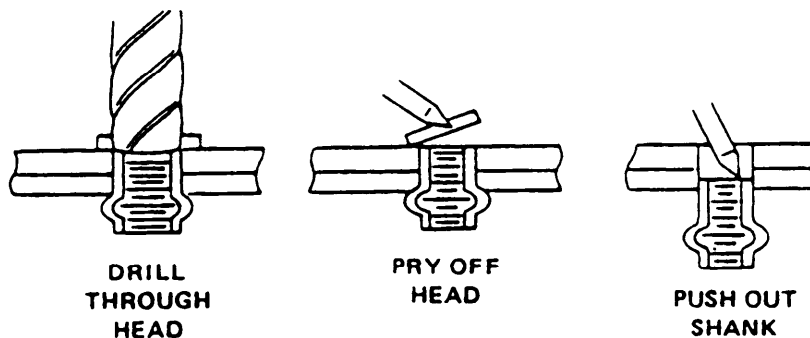

4753-012

Figure 3-8. Removing Rivnuts.

**CAUTION**

Do not puncture opposite face sheet of panel when punching out rivnut shank.

- (c) Punch out shank of rivnut, using a pin punch slightly smaller than hole in structure. Punch only enough to disengage. Move rivnut aside to install new rivnut.

*c. Temporary Panel Repair.* Any puncture in the shelter exterior, including punctures in the door skin, must be patched immediately to prevent water intrusion. In shelters with RFI/EMI shielding, any rupture of the future sheet must be patched immediately to prevent radiation leakage. Dents without pictures do not require patching. However, if bare metal is exposed, touchup paint shall be applied (para 3-10).

<p>Materials/Parts:</p> <ul style="list-style-type: none"> <li>Adhesive (items 2,3,4 or 5, Appendix D)</li> <li>Tape, pressure sensitive (Item 35, Appendix D)</li> <li>Electrically conductive tape (for shielded shelters) (Item 32, Appendix D)</li> </ul>	<ul style="list-style-type: none"> <li>Sandpaper, grit nos. 40,60 and 80 (Items 26,27 and 28, Appendix D)</li> <li>Clean Cloths (Item 9 or 10, Appendix D)</li> <li>Solvent (item 37, Appendix D)</li> <li>Gloves (Item 12, Appendix D)</li> <li>Goggles (item 38, Appendix D)</li> </ul>
---	---

**CAUTION**

Paint strippers can contaminate panel core, adhesive and sealers. Do not use paint strippers to remove paint.

RFI/EMI shielded shelters should not be used until an RFI/EMI suppression patch has been applied.



**NOTE**

Ceiling panel composition is the same as wall panel composition. The same method of repair applies to walls and ceilings.

- (1) Bend edges of puncture in below surface of unbroken face sheet. Do not allow broken edges to contact opposite face sheet.
- (2) Remove loose fragments of foam and dust.

**WARNING**

Solvents are flammable and toxic. Keep away from heat and open flames. Use in a well-ventilated area. Avoid skin and eye contact and breathing of vapors. Use protective goggles and gloves. Use in accordance with manufacturer's instructions.

- (3) Clean and dry area surrounding puncture using clean cloth soaked with solvent. Wipe off solvent. In shelters with RFI/EMI shielding, sand off all paint and foreign matter from face sheet surrounding damaged area at least 1-1/2 inches in all directions. Clean and dry bare metal.
- (4) Inject adhesive into puncture.
- (5) Apply a bead of adhesive approximately 1/4 inch wide over cuts in face sheet. Do not smooth out.

**NOTE**

In shelters having RFI/EMI shielding, perform steps (6) and (7) using electrically conductive tape, then repeat the procedure using non-conductive tape. In unshielded shelters, perform steps (6) and (7) only once using non-conductive tape.

- (6) Plan application of tape. Length and width, number of strips, overlaps and method of application will affect sealing capability of repair. Each piece of tape shall extend approximately 1-1/2 inches beyond adhesive. If width of damaged area exceeds width of tape, overlap tape strips at least 1/2 inch. If three or more strips of tape are required, apply center strip first.
- (7) Hold tape taut and apply lightly. Do not apply with rolling motion from end to end or side to side and do not rub strips into place. Rolling, rubbing and excessive pressure will squeeze adhesive out from under tape.
- (8) Touch up with paint as required (para 3-10).

**3-10. Touchup Painting.** When required to prevent rust and corrosion, touch up small areas of damaged or chipped paint in accordance with TM 43-0139. If a large area needs repainting, notify higher level of maintenance.

---

### 3-11. Door Brace Assembly.

---

This task covers:      a. Service      b. Remove      c. Disassemble      d. Assemble      e. Install

---

#### INITIAL SETUP

*Tools*

*Materials/Parts*

General Mechanic's Automotive Tool Kit  
SC 5180-90-CL-N26

Sealer (Item 29 or 30, Appendix D)  
Cotter Pin MS24665-285  
Lubricant (Item 17, Appendix D)

---

*a. Service.* Servicing of the door brace assembly consists of lubricating moving parts. Refer to paragraph 3-1 for lubrication instructions.

*b. Remove. (figure 3-9)*

- (1) Remove shoulder screw (1), self-locking nut (2) and flat washer (3) and detach upper brace (4) from door stop angle (5).
- (2) Remove wood screw (6) attaching chain end of chain and pin assembly (7) to door.

**NOTE**

If bracket (9) and screws (8) are in good condition and do not require replacement, omit step (3).

- (3) Remove ten screws (8) attaching bracket (9) to door and remove door brace assembly.

*c. Disassemble. (figure 3-9)*

- (1) Remove cotter pin (10) from pin of chain and pin assembly (7) and remove chain and pin assembly. Separate brace from bracket (9).
- (2) Push out roll pin(11) and remove catch (12).
- (3) Remove shoulder screw (13), self-locking nut (14) and flat washer (15) and separate upper brace (4) from lower brace (16).

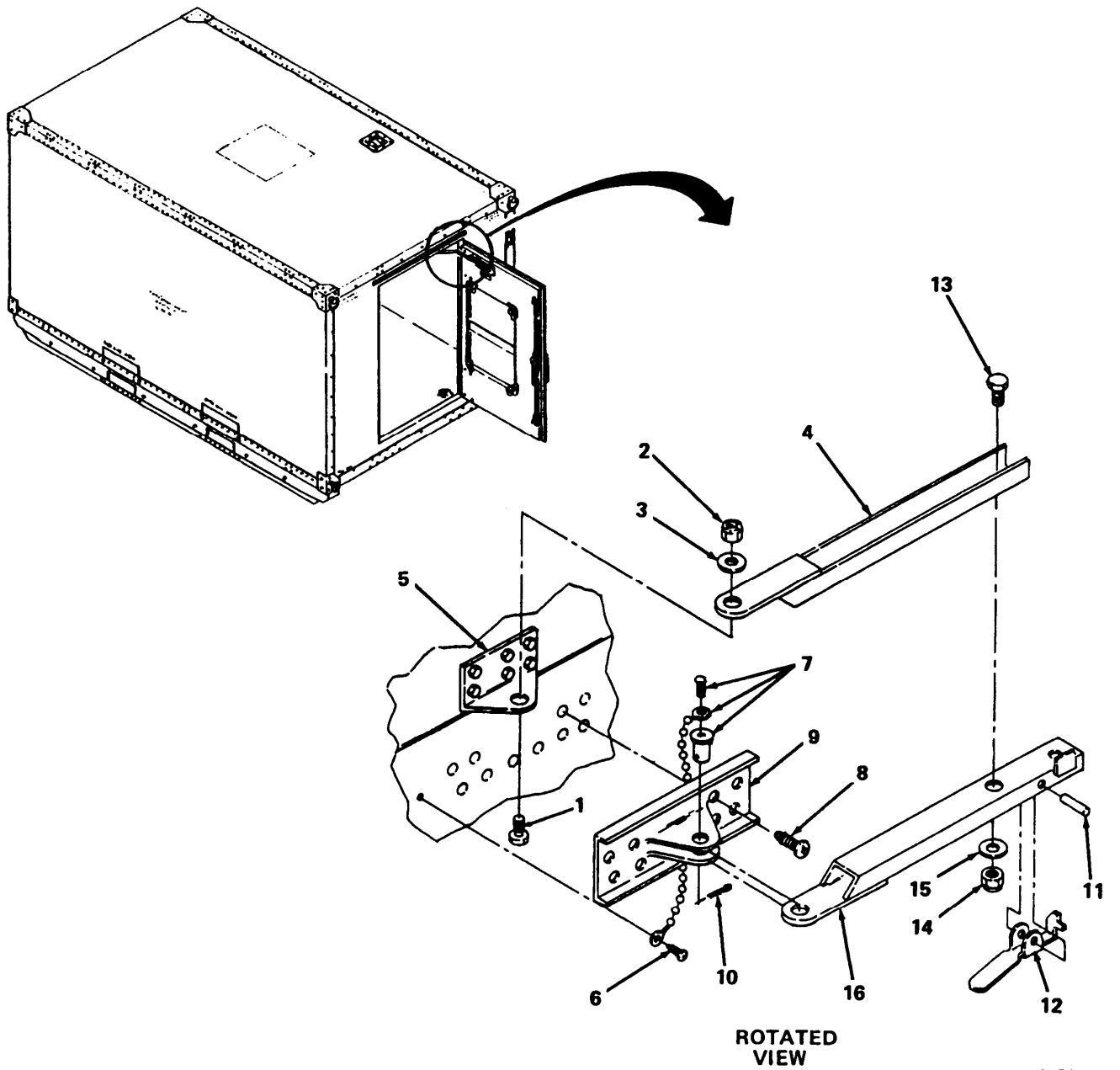

4753-013

Figure 3-9. Door Brace Assembly Removal and Disassembly.

3-11. Door Brace Assembly (cont).

d. Assemble. (figure 3-10)

- (1) Position upper brace (1) on lower brace (2) so that screw holes line up, and install shoulder screw (3), flat washer (4) and self-locking nut (5).
- (2) Position catch (6) on lower brace (2) and install roll pin (7).
- (3) Position tongue of lower brace (2) on bracket (8). Insert pin of chain and pin assembly (9) down through bracket and brace. Secure with cotter pin (10).

e. Install. (figure 3-10)

**NOTE**

If bracket (8) was not removed from door during removal, omit step (1).

- (1) Position bracket (8) on door and fasten with ten screws (11)
- (2) Mount chain end of chain and pin assembly (9) to door with wood screw (12).
- (3) Position free end of upper brace (1) against bottom of door stop angle (13) and install shoulder screw (14), flat washer (15) and self-locking nut (16).

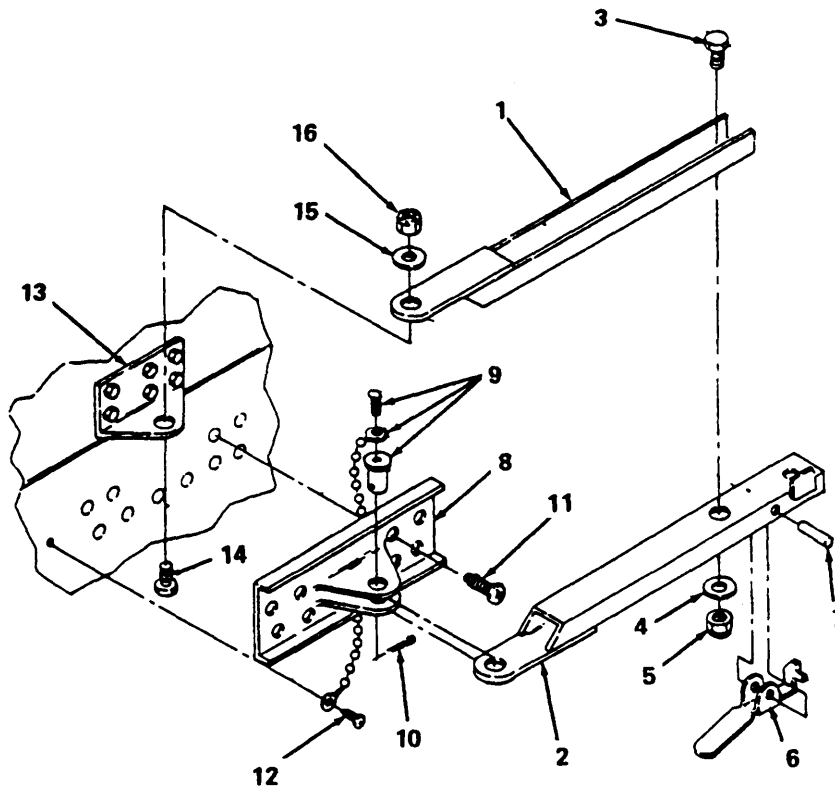

Figure 3-10. Door Brace Assembly Reassembly and Installation.

4753-014

---

**3-12. Door Assembly.**

---

This task covers:      Service and Repair

---

**INITIAL SETUP***Tools**Materials/Parts*

As applicable

As applicable

---

*Service and Repair.* Service and repair of the door assembly is covered in the following referenced paragraphs:

- (1) Emergency exit panel assembly replacement (para 3-13).
- (2) T-latch and holder replacement para 3-14).
- (3) Door latch assembly repair and replacement (para 3-15).
- (4) Air inlet filter replacement (para 3-16).

### 3-13. Emergency Exit Panel Assembly.

This task covers:      a. Service                      b. Repair                      c. Replace

#### INITIAL SETUP

*Tools*

General Mechanic's Automotive Tool Kit  
SC 5180-90-CL-N26

*Materials/Parts*

Lubricant (Item 17, Appendix D)

*a. Service.* Servicing of the emergency exit panel assembly consists of lubricating moving parts. Refer to paragraph 3-1 for lubrication instructions.

*b. Repair.* Repair of the emergency exit panel at unit level is limited to temporary repair of punctures in the aluminum. Refer to paragraph 3-9.c for repair procedures.

*c. Replace.* (figure 3-11)

- (1) Make sure emergency exit cover (1) is secured with latches (2) before removing emergency exit panel assembly (3) from door.
- (2) Remove four knobs (4) by turning each one Counterclockwise.
- (3) Pull emergency exit panel assembly (3) forward and out of door.
- (4) Position emergency exit panel assembly (3) in cutout in door.
- (5) install one knob (4) through each retainer (5) and into corner of emergency exit panel assembly (3) and tighten.

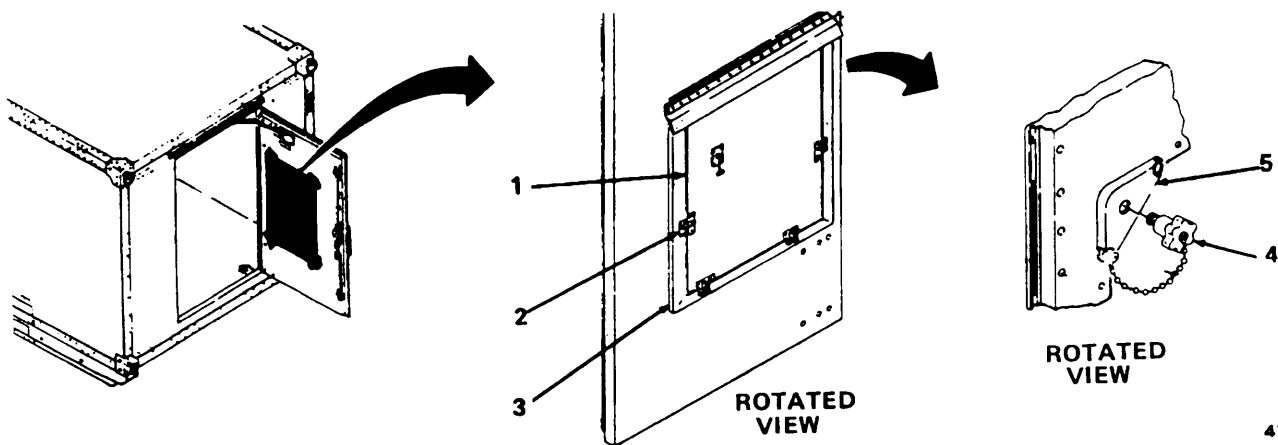

4753-015

**Figure 3-11. Emergency Exit Panel Assembly Replacement.**

---

**3-14. T-Latches and Holders.**

---

This task covers:      Replace

---

**INITIAL SETUP**
*Tools*

General Mechanic's Automotive Tool Kit  
SC 5180-90-CL-N26

*Materials/Parts*

Sealer (Item 29 or 30, Appendix D)  
Rivets, various  
Goggles (Item 38, Appendix D)  
Gloves (Item 12, Appendix D)

*General Safety Instructions*

---

**WARNING**

Drilling creates metal chips which may enter eyes and cause serious injury. Eye protection is required.

**NOTE**

The shelter has two T-latches. Replacement procedures are the same for both.

*Replace. (figure 3-12)*

- (1) Drill out four rivets (1) and remove T-latch (2). (Refer to paragraph 3-9a. for rivet removal instructions.)
- (2) Remove four screws (3), four flat washers (4), four lockwashers (5) and four nuts (6) and remove latch holder (7) from shelter wall.
- (3) Position latch holder (7) on shelter wall and fasten with four screws (3), four flat washers (4) four lockwashers (5) and four nuts (6).
- (4) Position T-latch (2) on shelter and fasten with four rivets (1). (Refer to paragraph 3-9a. for rivet installation instructions.)

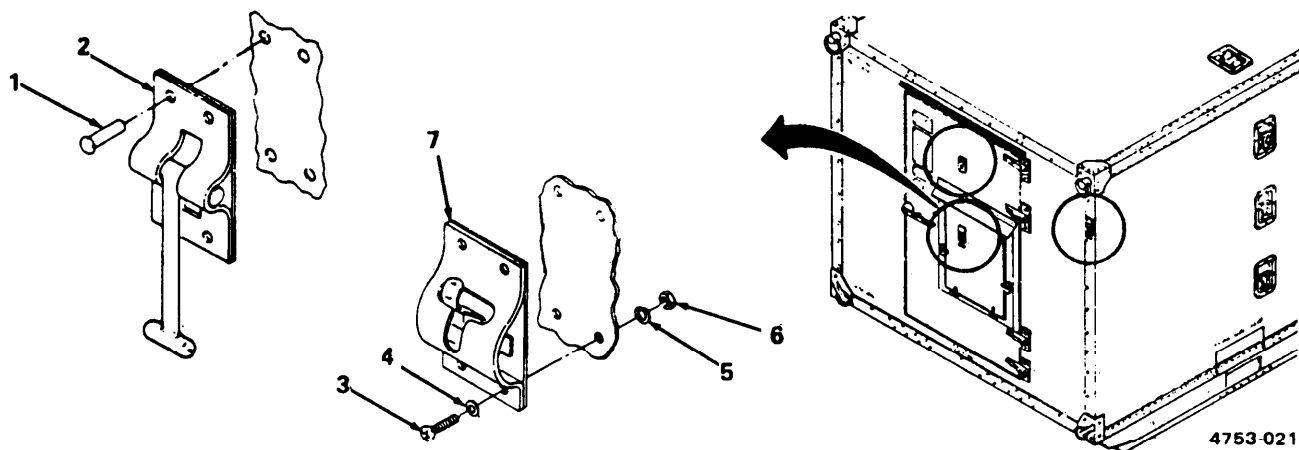

**Figure 3-12. T-Latch and Holder Replacement.**

---

3-15. **Door Latch Assembly.**

---

This task covers:    a. Remove and Disassemble    b. Inspect and Service    c. Assemble and Install

---

INITIAL SETUP

*Tools*

General Mechanic's Automotive Tool Kit  
SC 5180-90-CL-N26

*Materials/Parts*

Keeper Shims, PN SC-B-200153  
Lubricant, Silicone (Item 18, Appendix D)  
Sealer (Item 29 or 30, Appendix D)  
Shield Compound (Item 11, Appendix D)  
Washer Shims, PN SC-D-200140-8

---

*a. Remove and Disassemble. (figure 3-13)*

- (1) Push out three spring pins (1) and remove three pins (2) and three flat washers (3) attaching ends of latch rod assemblies (4) to latch arm assemblies (5). Remove latch rod assemblies.
- (2) Remove two self-locking nuts (6) and two flat washers (7) and remove upper and lower latch arm assemblies (5) from threaded ends of carriage bolts (8). Remove one spacer (9) from each latch arm assembly.

**NOTE**

Detent (10) is only located on bottom carriage bolt. Spacer(11) is only located on top carriage bolt.

- (3) Remove detent (10), spacer (11), shim washers (12) and spacers (13) from carriage bolts (8). Pull carriage bolts out of door.
- (4) Punch out spring pin (14) and take handle (15) off inside of door.
- (5) Punch out grooved pin (16) and take middle latch arm assembly (5) off inside of door.
- (6) Unscrew bearing sleeve nut (17) from handle shaft bearing sleeve (18) on inside of door.
- (7) Pull handle assembly (29 through 32) and handle shaft bearing sleeve (18) out of door.
- (8) Remove screw (19) and lockwasher (20), and remove padlock and key (21).
- (9) Remove two wood screws (22) and remove escutcheon plate (23) from outside of door.
- (10) Remove two cap screws (24) and two lockwashers (25) from each of three keepers (26) and remove keepers. Remove all shims (27). Record number and thickness of shims removed.
- (11) Remove latch lock assembly from middle (tapped) keeper (26) by unscrewing pin (28).



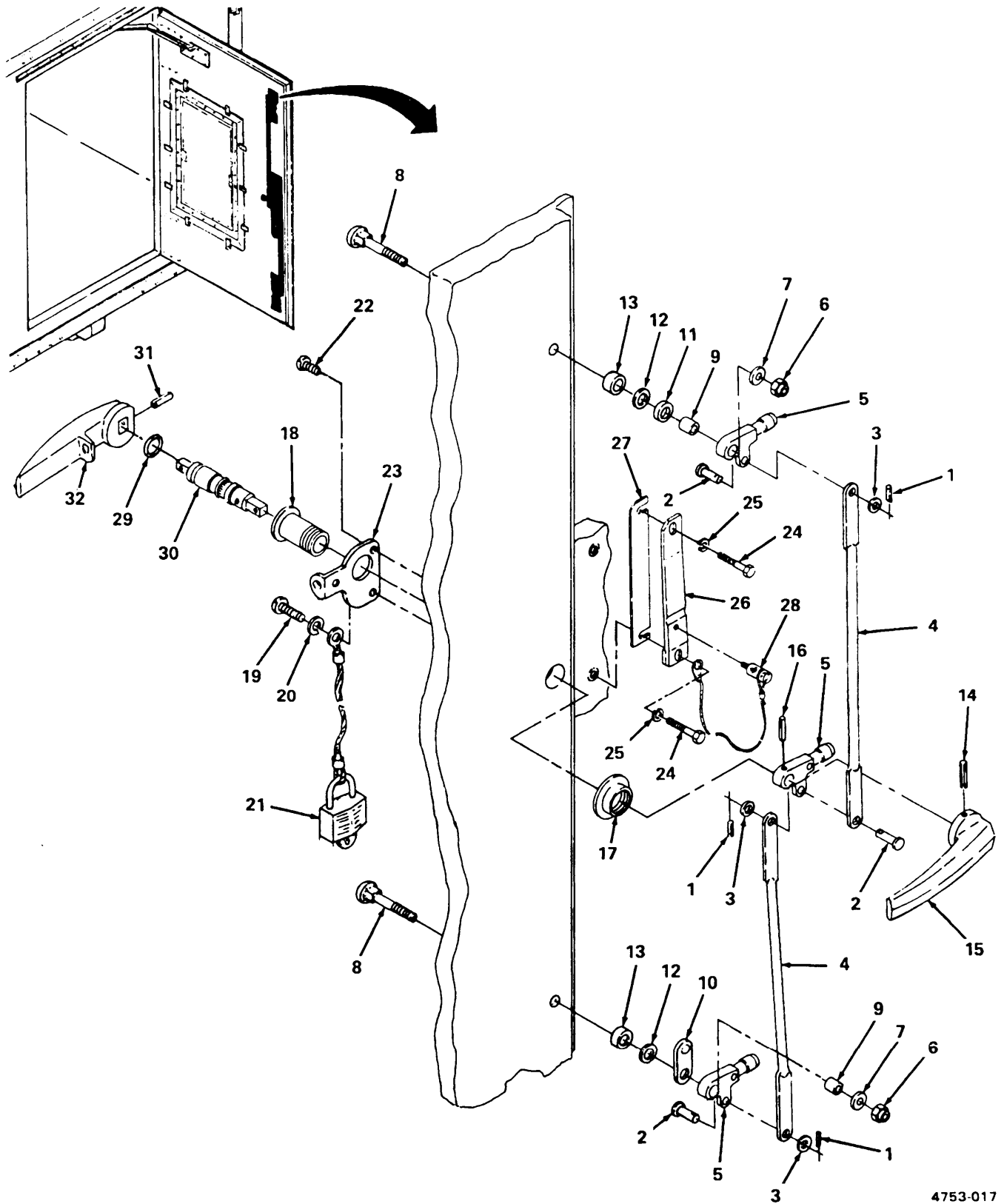

4753-017

Figure 3-13. Door Latch Assembly Removal and Disassembly.

**3-15. Door Latch Assembly (cont).**

---

**NOTE**

Disassemble handle assembly (step (12)) only if damage is suspected.

(12) Slip O-ring (29) off latch handle shaft (30). Punch out spring pin (31) and take handle (32) off latch handle shaft.

*b. Inspect and Service.*

(1) Check condition of all pins. Replace any pin that is bent, corroded or otherwise deteriorated.

(2) Clean and inspect threads of threaded parts. Inspect threaded inserts for thread damage and replace if necessary.

(3) Lubricate all moving parts with silicone lubricant before reassembling.

*c. Assemble and Install. (figure 3-14)*

**NOTE**

If handle assembly (1) through (4) was not disassembled during removal and disassembly, omit step (1).

(1) Install handle (1) on latch handle shaft (2) so that pin holes line up. Insert spring pin (3). Slip O-ring (4) over latch handle shaft and into groove.

**NOTE**

Only the middle keeper is tapped for installation of a latch lock assembly.

(2) Thread latch lock assembly pin (5) into tapped hole in tapped keeper(6).

(3) Stack shim(s) (7) against bottom of keeper (6), using number and thickness of shims recorded during disassembly. Position tab (8) of latch lock assembly over mounting hole at raised end of keeper.

**NOTE**

Two different length screws are used to fasten the keeper.

(4) Position keeper (6) and shims (7) on shelter wall so that mounting holes lineup and raised end of keeper is at the bottom. Install long screw (9) with lockwasher (10) through latch lock assembly tab (8) and raised end of keeper and into threaded insert in shelter wall. Install short screw (11) with lockwasher (10) in second mounting hole.

(5) Repeat steps (3) and (4) for two remaining keepers (7), omitting latch lock assembly.



**3-15. Door Latch Assembly (cont).**

---

**NOTE**

Use of shield compound is only required on RFI/EMI shielded shelters.

- (6) Apply shield compound to surface of door around handle mounting hole where surface will mate with escutcheon plate (12).
- (7) Position escutcheon plate (12) on outside of door over handle mounting hole and install two wood screws (13).
- (8) Position tab of padlock and key (14) over remaining mounting hole in escutcheon plate(12) and install screw (15) and lockwasher (16).
- (9) Apply shield compound to underside of flange of handle shaft bearing sleeve (17). Insert handle shaft bearing sleeve through door. Thread bearing sleeve nut (18) onto handle shaft bearing sleeve inside door and tighten until flange of handle shaft bearing sleeve tightens against escutcheon plate (12).
- (10) Insert handle assembly ((1 ) through (4)) into handle shaft bearing sleeve (17).
- (11) Position latch arm assembly (19) on handle assembly shaft (2) so that pin holes line up. Install grooved pin (20).
- (12) Position handle (21) on end of handle assembly shaft (2) so that pin holes line up. Install spring pin (22).

**NOTE**

Use same number of shim washers (25) with both carriage bolts (23).

- (13) Install two carriage bolts (23) in door. Install spacer (24) and shim washers (25) on each carriage bolt.
- (14) Install spacer (26) on top carriage bolt (23). Install detent (27) on bottom carriage bolt.
- (15) Insert one spacer (28) in each latch arm assembly (29). Position one latch arm assembly on each carriage bolt so that roller is pointing outboard. Secure each latch arm assembly with one flat washer (30) and one self-locking nut (31).
- (16) Measure distance between surface of each latch arm assembly (19 and 29) and plane of door surface. All three rollers should be aligned within .031 in (.079 cm). Add or subtract shims (25), as required, to achieve correct alignment.
- (17) Position one end of each latch rod assembly (32) against top and bottom latch arm assemblies (29) so that pin holes line up. Insert pins (33), install flat washers (34) and secure with spring pins (35).
- (18) Position remaining ends of each latch rod assembly (32) against middle latch arm assembly (19). Insert pin (36), install flat washer (37) and secure with spring pin (38).

- (19) Check latch torque. Latch torque should be 15 foot-pounds (max.) without RFI/EMI shielding gasket, or 30 foot-pounds (max.) with gasket installed. Adjust torque by adding or subtracting keeper shims (7).
- (20) Apply a bead of sealer around edges of escutcheon plate (12) and handle shaft bearing sleeve (17).
- (21) Lubricate as required (para 3-1).









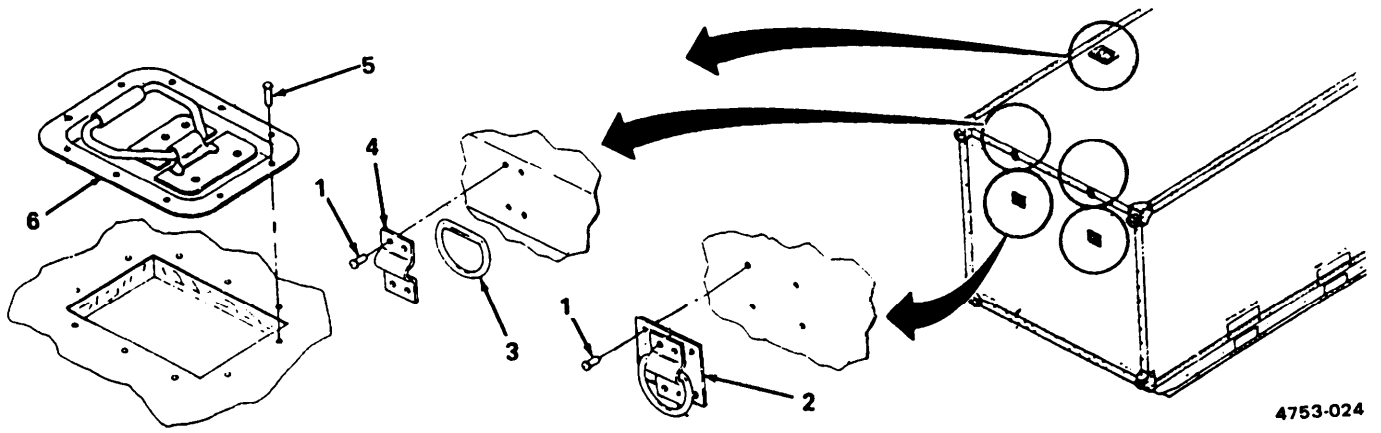

Figure 3-17. D-Ring Assembly Replacement.

---

### 3-19. Drain Plug and EMI Washer.

---

This task covers:     Replace

---

#### INITIAL SETUP

*Tools*

General Mechanic's Automotive Tool Kit  
SC 5180-90-CL-N26

*Materials/Parts*

Sealer (Item 29 or 30, Appendix D)

---

*Replace. (figure 3-18)*

- (1) Unscrew wood screw (1) and pull drain plug (2) out of floor drain.

**NOTE**

Step (2) applies to S-280B/G Shielded shelters only.

- (2) Check condition of RFI/EMI washer (3) and replace if necessary.
- (3) Insert drain plug (2) firmly in floor drain.
- (4) Insert wood screw (1) through tab of drain plug chain and into floor.

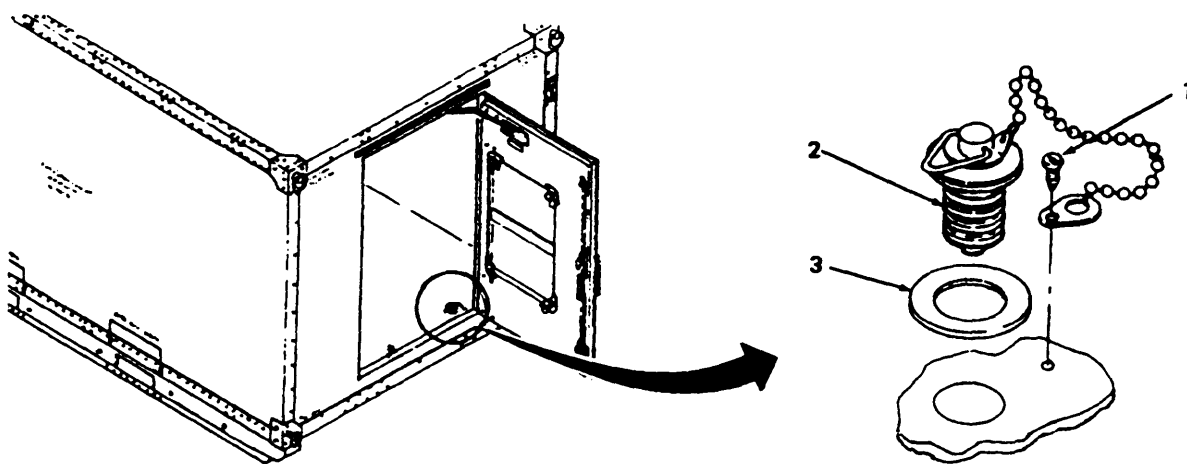

4753-025

**Figure 3-18. Drain Plug and EMI Washer Replacement.**

**3-20. RFI/EMI Components.**

This task covers:      Replace

INITIAL SETUP

*Materials/Parts*

Washer, PN SM-B-374181

*Replace.* RFI/EMI component replacement is limited to replacement of the EMI washer (para 3-19).

**Section IV. PREPARATION FOR SHIPMENT AND STORAGE**

Subject	Para	Page
General . . . . .	3-21	3-35
Loading Shelter into ANSI/ISO Container . . . . .	3-22	3-35
General Storage Requirements . . . . .	3-23	3-35
Administrative Storage . . . . .	3-24	3-35

3-21. **General.** No special preparation is required for shipment of the shelter other than making sure the correct sling assembly is available and in good condition, the skids are in good condition and securely mounted to the shelter, and the drain plug is loosened for air or rail transport.

3-22. **Loading Shelter into ANSI/ISO Container.** Shelters maybe shipped in Type IAA ANSI/ISO containers only when crated or pallet-mounted. Block crates or pallets securely in the container to prevent movement and damage during transit. Install and remove shelters in accordance with TB 11-5400-200-14.

3-23. **General Storage Requirements.** Accumulation of moisture within the shelter resulting from temperature and humidity fluctuations can damage equipment. Minimize moisture accumulation by keeping shelter doors, louver covers and drain holes open during indoor storage. During outdoor storage, keep doors and drain holes closed, but keep louver covers open. A free breather assembly may also be used, when available, to absorb moisture inside the shelter. When using the free breather assembly, doors, louver covers and drain holes must be closed. For usage information, refer to the applicable drawing for the particular free breather assembly being used.

**3-24. Administrative Storage.**

a. Placement of equipment in administrative storage should be for short periods of time when a shortage of maintenance effort exists. Items should be in mission readiness within 24 hours or within the time factors as determined by the directing authority. During the storage period appropriate maintenance records will be kept.

b. Before placing equipment in administrative storage, current maintenance services and equipment serviceable criteria (ESC) evaluations should be completed, shortcomings and deficiencies should be corrected, and all modification work orders (MWO's) should be applied.

c. Storage site selection. Inside storage is preferred for items selected for administrative storage.

CHAPTER 4

DIRECT SUPPORT MAINTENANCE INSTRUCTIONS

Subject	Section	Page
Repair Parts, Special Tools, TMDE and Support Equipment. . . . .	I	4-1
Troubleshooting. . . . .	II	4-1
Direct Support Maintenance procedures. . . . .	III	4-3

**Section I. REPAIR PARTS, SPECIAL TOOLS, TMDE AND SUPPORT EQUIPMENT**

Subject	Para	Page
Common Tools. . . . .	4-1	4-1
Special Tools, TMDE and Support Equipment. . . . .	4-2	4-1
Repair Parts. . . . .	4-3	4-1

4-1. **Common Tools.** A complete list of common tools and tool kits is given in Section III of Appendix B, Maintenance Allocation.

4-2. **Special Tools,** TMDE and Support Equipment. There are no special tools or equipment needed to maintain the shelters.

4-3. **Repair Parts.** Repair parts for direct support maintenance of the shelters are listed and illustrated in TM 10-5411-206-24P.

**Section II. TROUBLESHOOTING**

4-4. **Troubleshooting.** This section contains troubleshooting information for malfunctions which may develop in the shelters. Fault isolation is limited to those components which may be repaired or replaced at the direct support level. Table 4-1 lists the common malfunctions you may encounter during operation or maintenance of the shelter. Each malfunction is followed by a list of tests or inspections and corrective actions. These tests or inspections and corrective actions should be performed in the order listed. This manual cannot list all malfunctions that may occur. If you encounter a malfunction that is not listed or cannot be corrected by the listed corrective actions, notify your supervisor.

Table 4-1. Troubleshooting.

MALFUNCTION	TEST OR INSPECTION	CORRECTIVE ACTION
-------------	--------------------	-------------------

1. WATER IS GETTING INTO SHELTER

- Step 1. Check condition of weather gaskets on door and emergency exit panel.
  - Replace deteriorated gaskets (para 4-12).
- Step 2. Check condition of drip cap and drip mold.
  - Replace defective drip cap (para 4-13) or drip mold (para 4-7).
- Step 3. Inspect shelter walls and ceiling for leaks.
  - Patch any holes (para 4-20).
- Step 4. Check to see that all exterior wall and ceiling patches are firmly mounted and bonded to shelter wall.
  - Apply sealer around edge of patch, or replace patch (para 4-20).
- Step 5. Check to see if louver assembly is installed backwards. Louvers should aim down toward the outside.
  - Remove intake louver assembly and reinstall correctly (para 4-15).
- Step 6. Check to see if lifting eye assemblies or towing eye assemblies have pulled away from shelter corners.
  - a. Apply sealer to gaps around bracket edges.
  - b. If replacement is required, notify higher level of maintenance.

2. THERE IS EVIDENCE OF RADIO FREQUENCY/ELECTROMAGNETIC INTERFERENCE (S-280B/G SHIELDED)

- Step 1. Inspect shelter walls, ceiling and floor for holes.
  - Patch any holes (para 4-20).
- Step 2. Check to see that all exterior wall and ceiling patches are firmly mounted and bonded.
  - Replace poorly mounted patches and replace all temporary tape patches with permanent aluminum patches (para 4-20).

Table 4-1. Troubleshooting (cont).

MALFUNCTION	TEST OR INSPECTION	CORRECTIVE ACTION
	Step 3. Check condition of RFI/EMI filter in door.	Replace damaged or missing filter (para 4-15).
	Step 4. Check for missing hinge shims.	Replace missing shims (para 4-17).
	Step 5. Check condition of metal door gasket.	If replacement is required, notify higher level of maintenance.

**Section III. DIRECT SUPPORT MAINTENANCE PROCEDURES**

Subject	Para	Page
General . . . . .	4-5	4-3
Surface Preparation, Priming and Painting . . . . .	4-6	4-3
Drip Mold . . . . .	4-7	4-4
Data Plates . . . . .	4-8	4-5
Door Stop Angle . . . . .	4-9	4-6
Floor Tread . . . . .	4-10	4-7
Door Assembly . . . . .	4-11	4-8
Weather Gaskets . . . . .	4-12	4-9
Drip Cap . . . . .	4-13	4-11
Emergency Exit Latches, Strikes and Stud Plate Assemblies . . . . .	4-14	4-12
Intake Louver Assembly and RFI Fitter . . . . .	4-15	4-14
Door Knob Assemblies . . . . .	4-16	4-16
Door Hinge Assemblies . . . . .	4-17	4-18
Door Skin . . . . .	4-18	4-20
RFI/EMI Components . . . . .	4-19	4-21
Wall Floor and Ceiling Panels . . . . .	4-20	4-22

4-5. **General** This section contains maintenance procedures which are the responsibility of direct support maintenance, as authorized by the Maintenance Allocation Chart (appendix B). The general maintenance information given for unit level maintenance also applies to direct support level maintenance. This information is contained in paragraph 3-8.

4-6. **Surface Preparation, Priming and Painting.** All bare metal shall be painted to prevent corrosion. Touch up small dents and chips. Repaired sections of panels must be prepared with a corrosion protection primer before painting. Do not attempt to repaint large areas such as complete exterior, interior ceiling. Detailed priming and painting instructions can be found in TM43-0139.

---

#### 4-7. Drip Mold.

---

This task covers:      Replace

---

##### INITIAL SETUP

###### *Tools*

Electronic Equipment Shelter Tool Kit TK-1 44/G  
General Mechanic's Automotive Tool Kit  
SC 5180-90-CL-N26  
Blind Riveter

###### *General Safety Instructions*

##### **WARNING**

Drilling creates metal chips which may enter eyes and cause serious injury. Eye protection is required.

###### *Materials/Parts*

Sealer (Item 29 or 30, Appendix D)  
Rivets, Various  
Goggles (Item 38, Appendix D)

---

*Replace. (figure 4-1)*

- (1) Drill out seven rivets (1 and 2) and remove drip mold (3) from shelter wall. (Refer to paragraph 3-9.a for rivet removal instructions.)

##### **NOTE**

The last two rivet locations on each end of drip mold require longer grip range rivets than the middle three locations.

- (2) Position drip mold (3) on shelter wall and fasten with four long rivets (1) and three short rivets (2). (Refer to paragraph 3-9.a for rivet installation instructions.)

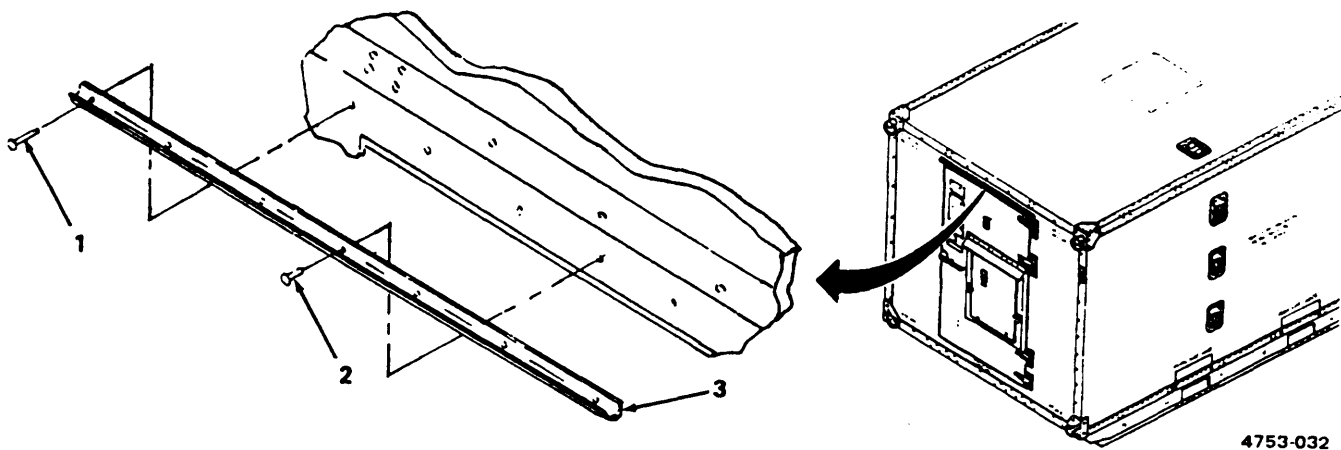

**Figure 4-1. Drip Mold Replacement.**

**4-8. Data Plates.**

This task covers:     Replace

INITIAL SETUP

*Tools*

Electronic Equipment Shelter Tool Kit  
 TK-144/G  
 General Mechanic's Automotive Tool Kit  
 SC 5180-90-CL-N26  
 Blind Riveter

*General Safety Instructions*

**WARNING**

Drilling creates metal chips which may enter eyes and cause serious injury. Eye protection is required.

*Materials/Parts*

Sealer (Item 29 or 30, Appendix D)  
 Rivets, Various  
 Goggles (Item 38, Appendix D)

*Replace. (figure 4-2)*

- (1) Drill out four rivets (1) and remove plate (2, 3,4, 5 or 6) from shelter wall. (Refer to paragraph 3-9.a for rivet removal instructions.)
- (2) Position data plate (2, 3,4,5 or 6) on shelter wall and fasten with four rivets (1). (Refer to paragraph 3-9.a for rivet installation instructions.)

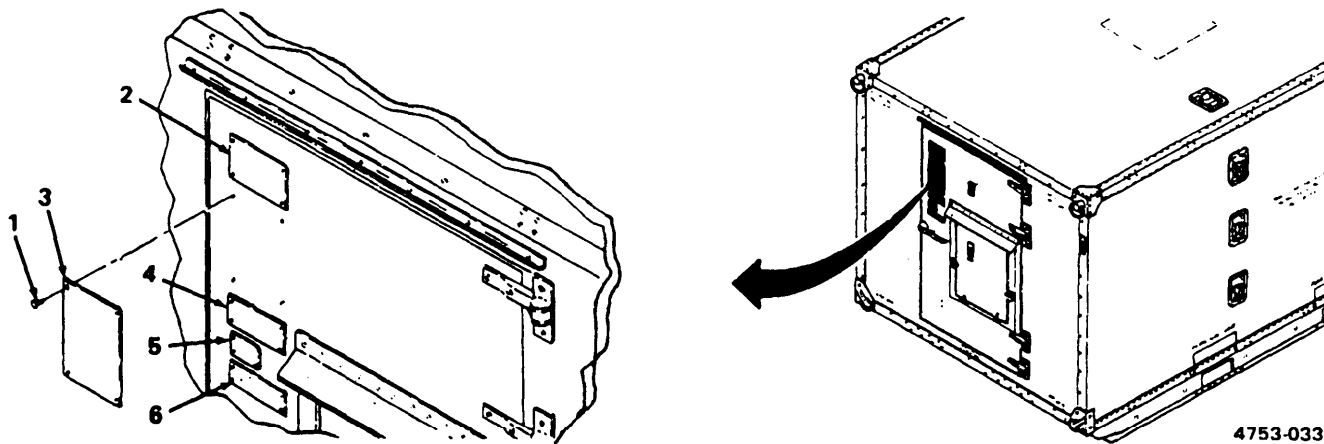

**Figure 4-2. Data Plate Replacement.**



#### 4-9. Door Stop Angle.

This task covers:      Replace

##### INITIAL SETUP

*Tools*

Electronic Equipment Shelter Tool Kit  
TK-144/G  
General Mechanic's Automotive Tool Kit  
SC 5180-90-CL-N26  
Blind Riveter

*Materials/Parts*

Sealer (Item 29 or 30, Appendix D)

*Replace. (figure 4-3)*

- (1) Remove shoulder screw (1), self-locking nut (2) and flat washer (3) and swing door brace (4) away from door stop angle (5).
- (2) Remove six bolts (6) and take door stop angle (5) off shelter wall.
- (3) Inspect rivnuts (7) and replace if necessary (para 3-9. b).
- (4) Position door stop angle (5) on shelter wall so that mounting holes line up with rivnuts (7) over door.
- (5) Install six bolts (6).
- (6) Position door brace (4) against underside of door stop angle (5) and fasten with shoulder screw (1), flat washer (3) and self-locking nut (2).

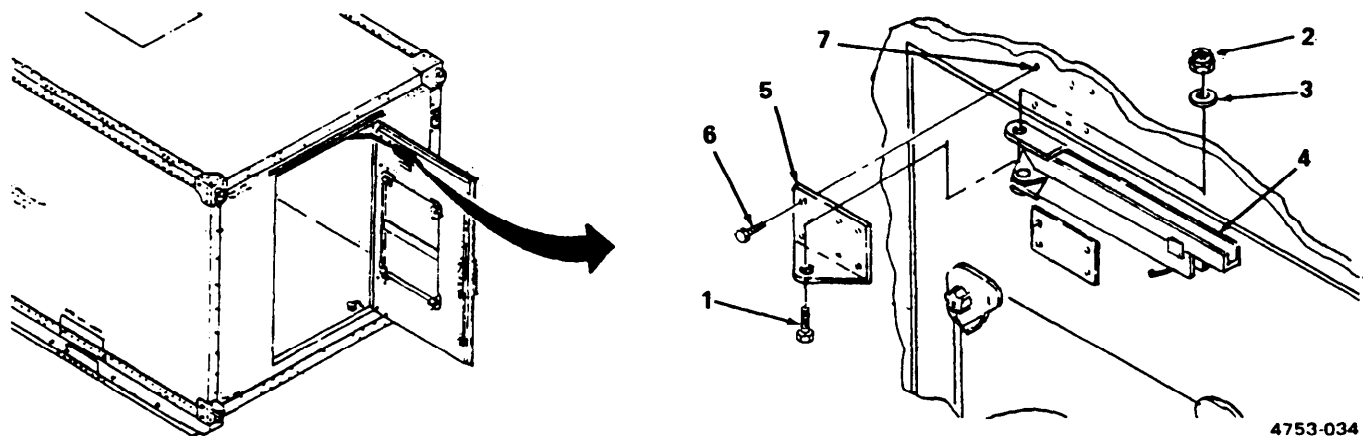

**Figure 4-3. Door Stop Angle Replacement.**

---

#### 4-10. Floor Tread.

---

This task covers:     Replace

---

##### INITIAL SETUP

##### *Tools*

Electronic Equipment Shelter Tool Kit  
TK-144/G  
General Mechanic's Automotive Tool Kit  
SC 5180 -90-CL-N26

##### *Materials/pads*

Solvent (Item 37, Appendix D)  
Rubber Floor Matting (Item 19 or 20, Appendix D)  
Gloves (Item 12, Appendix D)  
Goggles (Item 38, Appendix D)

---

##### *General Safety /nstructions*

#### **WARNING**

Solvents are flammable. Keep away from heat and open flames. Avoid eye and skin contact and breathing of vapors. Use protective goggles and gloves. Use in a well-ventilated area. Use in accordance with manufacturer's instructions.

##### *Replace.*

#### **CAUTION**

When removing floor tread that has been cemented down, be careful not to delaminate shelter floor.

#### **NOTE**

When installing new floor tread inside shelter, it is not necessary to remove old, worn floor tread that has been cemented down unless leaving it in place and covering it with new tread material will interfere with equipment or racks. If old tread is not being removed, omit steps (1) through (3).

- (1) Remove old floor tread completely.

#### **CAUTION**

Do not permit solvent to penetrate through floor panels. Solvent may dissolve core material.

- (2) Remove residue using solvent. Wipe off solvent.
- (3) Prime and paint floor (para 4-6).
- (4) Cut new floor tread using 1/8 or 3/16 inch thick rubber floor matting. Lay new tread in place. Do not cement in place.

#### 4-11. Door Assembly.

---

This task covers:      Repair

---

##### INITIAL SETUP

###### *Tools*

As required

###### *Materials/Parts*

As required

###### *General Safety Instructions*

##### **WARNING**

Adhesives contain toxic solvents, Avoid eye and skin contact and breathing of vapors. Use in a well-ventilated area. Use protective goggles and gloves. Use in accordance with manufacturer's instructions.

Drilling creates metal chips which may enter eyes and cause serious injury. Eye protection is required.

---

Repair. Repair of the door assembly is covered in the following referenced paragraphs:

- (1) Weather gasket replacement (para 4-12).
- (2) Drip cap replacement (para 4-13).
- (3) Emergency exit latch, strike and stud plate assembly replacement (para 4-14).
- (4) Intake louver assembly and RFI filter replacement (para 4-15).
- (5) Doorknob assembly replacement (para 4-16).
- (6) Door hinge assembly replacement (para 4-17).
- (7) Door Skin (para 4-18).

---

#### 4-12. Weather Gaskets.

---

This task covers:      Replace

---

##### INITIAL SETUP

###### *Tools*

General Mechanic's Automotive Tool Kit  
 SC 5180-90-CL-N26  
 Electronic Equipment Shelter Tool Kit TK-144/G

###### *Materials/Parts*

Gasket, (Item 13, Appendix D)  
 Solvent (Item 37, Appendix D)  
 Adhesive (Item 2,3,4 or 5, Appendix D)  
 Primer (Item 23, Appendix D)  
 Gloves (Item 12, Appendix D)  
 Goggles (Item 38, Appendix D)

---

###### *General Safety Instructions*

##### **WARNING**

Solvents and adhesives are flammable and toxic. Keep away from heat and open flames. Avoid eye and skin contact and breathing of vapors. Use in a well-ventilated area. Use protective goggles and gloves. Use in accordance with manufacturer's instructions.

*Replace (figure 4-4)*

##### **NOTE**

Gaskets must be replaced when a permanent set occurs and the seal is no longer reliable. Weather gaskets can be found on the door assembly and emergency exit (inlet assembly). Replacement procedures are the same for all weather gaskets.

- (1) Carefully remove gasket and scrape channel clean.
- (2) Remove residue using solvent.

##### **NOTE**

Adhesive must be applied between 30 minutes and eight hours after application of primer. If original primer coat was not damaged during removal of old gasket, it is not necessary to apply new coat of primer.

- (3) Apply primer, then adhesive, evenly to sides and bottom of gasket channel to insure a continuous bond.
- (4) Immediately after applying adhesive, press new gasket into place.
- (5) Clamp gasket around each corner to ensure good gasket contact with channel bottom while adhesive cures. Gasket surface which mates with door jamb must be flat with no sharp discontinuities along its length, corners or joint while adhesive cures.

4-12. Weather Gaskets (cont).

- (6) Allow adhesive to cure at least 12 hours at 50% RH and 70°F (21°C). Lower humidity and temperatures require a longer cure time.
- (7) After adhesive has cured, fill gasket channel voids at each corner with adhesive so that it is flush with door. Bond gasket ends together with adhesive to form a tight joint. Do not fill gasket hollow section at joint.
- (8) Test gasket seating by inserting a piece of paper 0.005 inch (maximum) thick by 2-1/2 inches wide at center of top and bottom of door or cover and three places along each side. When door or cover is closed, paper should be trapped between weather gasket and mating surface (but not under RFI/EMI gasket in shielded shelters). If paper can be withdrawn without any resistance while door or cover is closed, gasket is not making good contact with mating surface. Correct as follows:
  - (a) Check condition of gasket. Replace gasket if it is in unsatisfactory condition, or if it is improperly installed (kinked or poorly spliced).
  - (b) If gasket is in good condition, gasket compression maybe increased by changing thickness of latch keeper shims (para 3-15) or hinge shims (para 4-17). Make sure latches contact their respective keepers when closed.
  - (c) After adjustments are made, make sure door cover is capable of opening and closing fully without binding.
  - (d) Repeat gasket seating test.

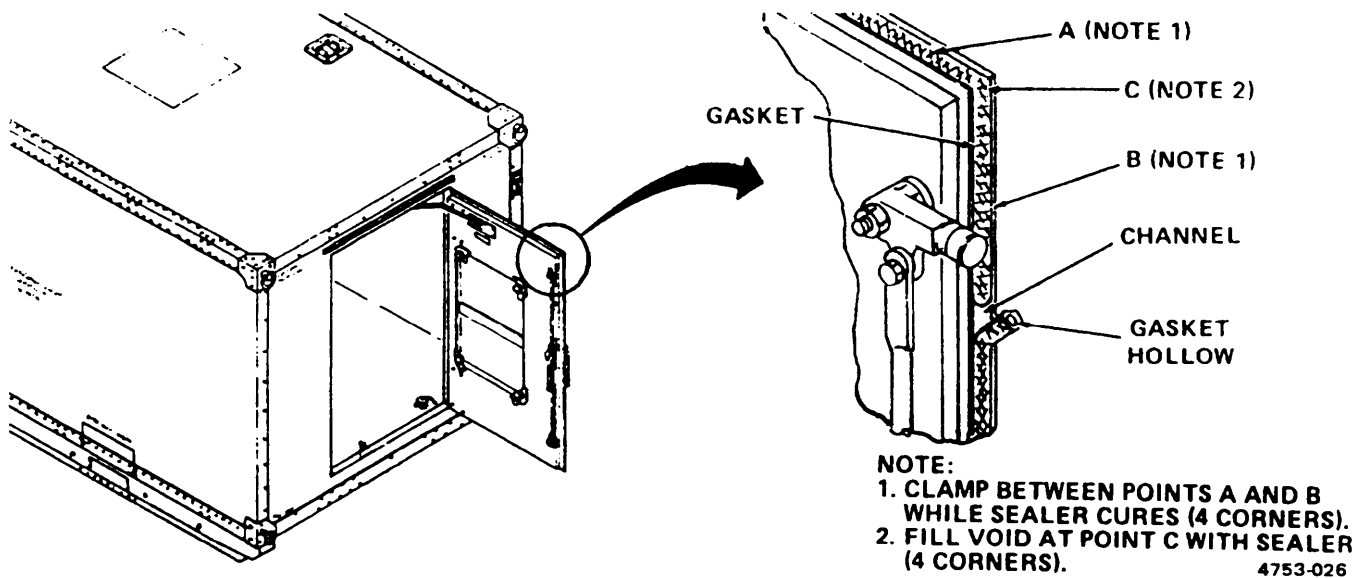

Figure 4-4. Weather Gasket Replacement.

---

## 4-13. Drip Cap.

---

This task covers:     Replace

---

### INITIAL SETUP

#### *Tools*

General Mechanic's Automotive Tool Kit  
 SC 5180 -90-CL-N26  
 Electronic Equipment Shelter Tool Kit TK-144/G  
 Blind Riveter

#### *Materials/Parts (cont)*

Rubber, Synthetic (Item 38, Appendix D)  
 Goggles (Item 38, Appendix D)  
 General Safety Instructions

#### *Materials/Parts*

Sealer (Item 29 or 30, Appendix D)  
 Rivnuts, various

### WARNING

Drilling creates metal chips which may enter eyes and cause serious injury. Eye protection is required.

---

### *Replace (figure 4-5)*

- (1) Drill out 17 rivets (1) and take drip cap strip (2) and drip cap (3) off door. (Refer to paragraph 3-9.a. for rivet removal instructions.)
- (2) Cut a new drip cap (3) out of rubber, using old drip cap as a template.
- (3) Using drip cap strip (2) as a template, punch 17 holes in edge of replacement drip cap (3).
- (4) Position drip cap (3) and strip (2) on shelter door and fasten with 17 rivets (1). (Refer to paragraph 3-9.a. for rivet installation instructions.)

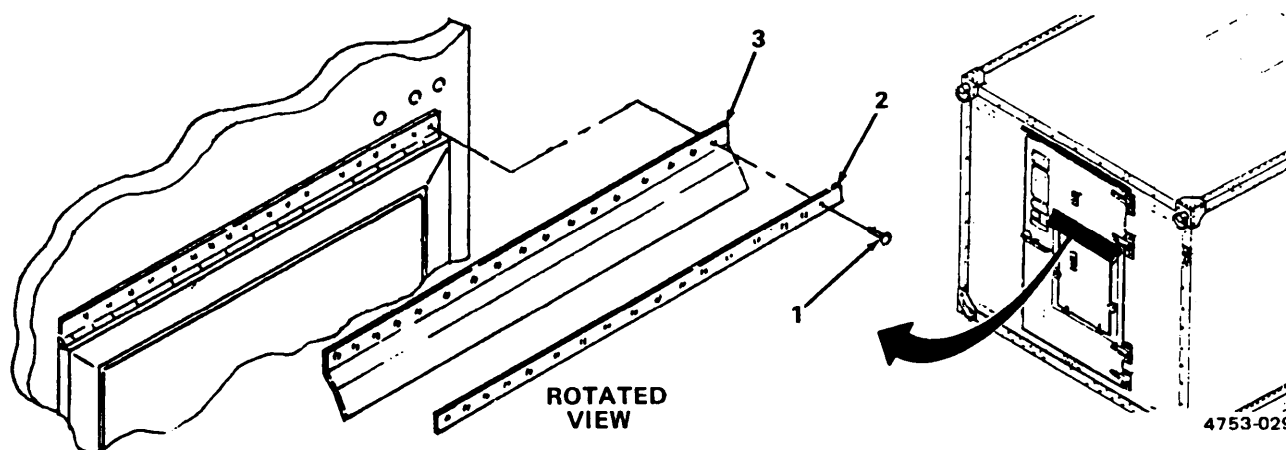

**Figure 4-5. Drip Cap Replacement.**

---

#### 4-14. Emergency Exit Latches, Strikes and Stud Plate Assemblies

---

This task covers:      Replace

---

##### INITIAL SETUP

###### *Tools*

General Mechanic's Automotive Tool Kit  
SC 5180 -90-CL-N26  
Blind Riveter

###### *Materials/Parts*

Sealer (Item 29 or 30, Appendix D)  
Rivnuts, various  
Goggles (Item 38, Appendix D)

---

###### *General Safety Instructions*

##### **WARNING**

Drilling creates metal chips which may enter eyes and cause serious injury. Eye protection is required.

*Replace (figure 4-6)*

##### **NOTE**

There are four latches, strikes and stud plate assemblies on the emergency exit panel. This procedure is typical for all four.

- (1) Remove self-locking nut (1) and flat washer (2) and take latch (3) and flat washer (4) off stud plate assembly (5).
- (2) Drill out two rivets (6) and remove stud plate assembly (5) from frame (7) of emergency exit panel. (Refer to paragraph 3-9.9 for rivet removal instructions.)
- (3) Drill out three rivets (8 and 9) and remove strike (10) from emergency exit panel cover (1 1). (Refer to paragraph 3-9a. for rivet removal instructions.)
- (4) Position strike (1 0) on emergency exit panel cover (1 1 ) and fasten with two countersunk head rivets (8) and one dome head rivet (9). (Refer to paragraph 3-9a. for rivet installation instructions.)
- (5) Position stud plate assembly (5) on frame (7) of emergency exit panel and fasten with two rivets (6). (Refer to paragraphs 3-9a. for rivet installation instructions.)
- (6) Slide flat washer (4), then latch (3), then second flat washer (2) onto stud of stud plate assembly (5). Secure with self-locking nut (1). Make nut just loose enough to permit hand operation of latch.

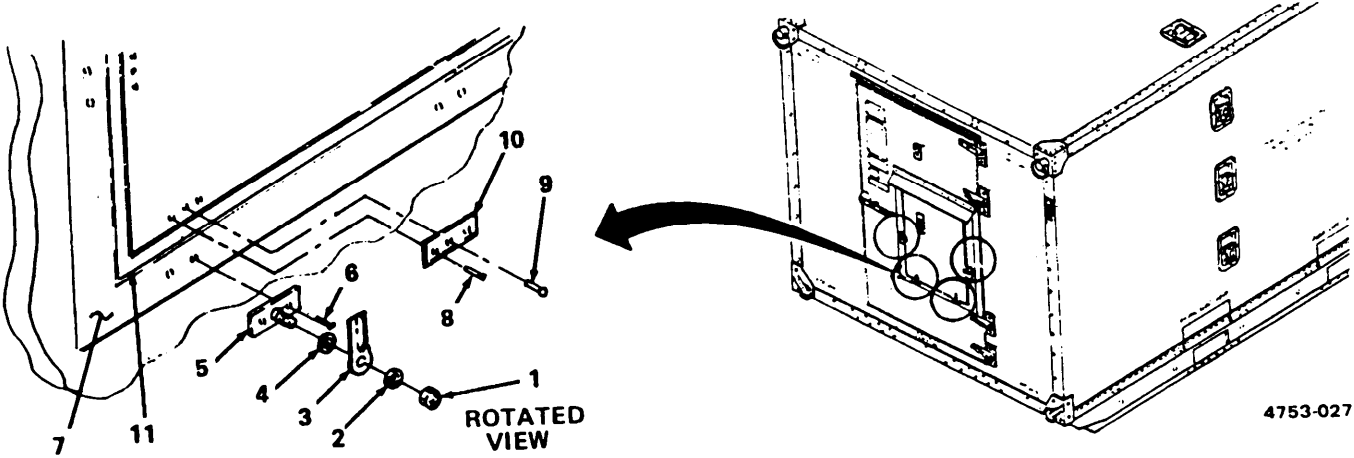

Figure 4-6. Emergency Exit Latch Strike and Stud Plate Assembly Replacement



---

#### 4-15. Intake Louver Assembly and RFI/EMI Filter.

---

This task covers:      Replace

---

##### INITIAL SETUP

<i>Tools</i>	<i>Personnel Required</i>
General Mechanic's Automotive Tool Kit SC 5180-90-CL-N26	Two
Electronic Equipment Shelter Tool Kit TK-144/G	Equipment Condition
<i>Materials/Parts</i>	Air inlet filter removed (para 3-16)
Sealer (Item 29 or 30, Appendix D) Tape SM-B-450436-1	

---

*Replace (figure 4-7)*

#### NOTE

Shielded shelters have an RFI/EMI filter mounted to the emergency exit frame, between the intake louver and the air inlet filter. When replacing the intake louver in a shelter without RFI/EMI shielding, omit the steps in this procedure that pertain to the RFI/EMI filter and tape.

- (1) Prop emergency exit cover (1) open.
- (2) Working on inside of emergency exit, unscrew 92 slotted screws (2), while assistant supports intake louver assembly (3) from outside.
- (3) Working on outside of emergency exit, take four retaining strips (4 and 5), intake louver assembly (3) and RFI/EMI filter (6) off frame (7). Peel off tape.
- (4) Install tape on all mating surfaces between frame (7) and flange of RFI/EMI filter (6).

#### NOTE

Make sure sealer is still wet when installing intake louver assembly (3) and retaining strips (4 and 5).

- (5) Coat both sides of flange of intake louver assembly (3) with sealer.
- (6) Working on outside of emergency exit, position RFI/EMI filter (6) against back of intake louver assembly (3) so that mounting holes in flanges line up.
- (7) While assistant holds intake louver assembly (3) and RFI/EMI filter (6) in position against frame (7), install eight comer slotted screws (2) from interior side of emergency exit.

- (8) Position retaining strips (4 and 5) on flange of intake louver assembly (3) so that previously installed corner screws (2) pass through end mounting holes of each retaining strip.
- (9) Working on inside of emergency exit, install remaining slotted screws (2).
- (10) Apply a bead of sealer around edge of flanges of intake louver assembly (3) and RFI/EMI filter (6).
- (11) Close emergency exit cover (1).

**NOTE**

**FOLLOW-ON MAINTENANCE:** Install air inlet filter (para 3-16).

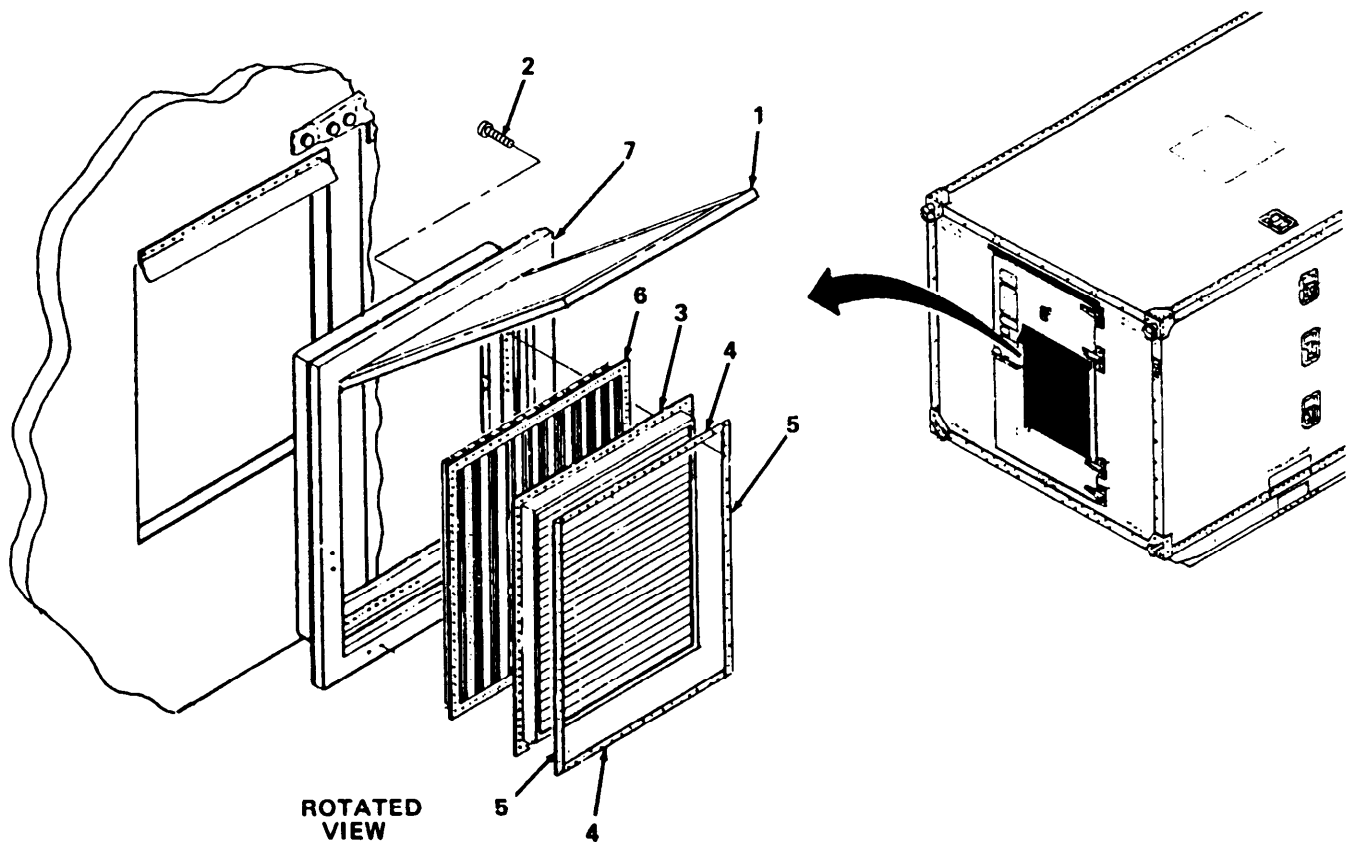

4753-028

**Figure 4-7. Intake Louver Assembly and RFI/EMI Filter Replacement.**

**4-I6. Door Knob Assemblies.**

---

This task covers:     Replace

---

INITIAL SETUP

*Tools*

*General Safety Instructions*

General Mechanic's Automotive Tool Kit  
SC 5180 -90-CL-N26

**WARNING**

Blind Riveter

Drilling creates metal chips which may enter eyes and cause serious injury. Eye protection is required.

*Materials/Parts*

Sealer (Item 29 or 30, Appendix D)  
Rivnuts, various  
Goggles (Item 38, Appendix D)

---

**NOTE**

There are four knob assemblies on inside of shelter door. This procedure is typical for all four.

*Replace. (figure 4-8)*

- (1) Unscrew knob (1) from retainer (2).
- (2) Drill out rivet (3) and remove knob assembly from retainer (2). Drill out rivet (4) and remove retainer from door. (Refer to paragraph 3-9.a. for rivet removal instructions.)

**NOTE**

Anchor tab of knob assembly chain to side rivets on top retainers and bottom rivets on bottom retainers.

- (3) Position retainer (2) on door and install one rivet (4). (Refer to paragraph 3-9.a. for rivet installation instructions.)
- (4) Screw knob (1) into retainer (2) and into frame of emergency exit.
- (5) Position tab (5) of knob assembly chain over second rivet hole in retainer (2) and install rivet (3).

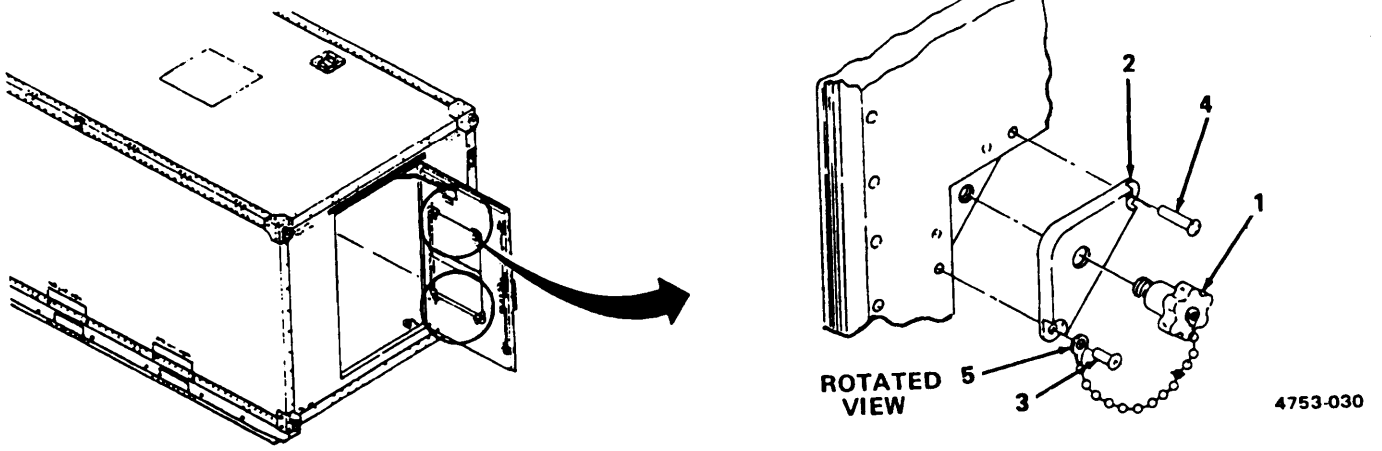

Figure 4-8. Door Knob Assembly Replacement.

---

## 4-17. Door Hinge Assemblies.

---

This task covers:     Replace

---

### INITIAL SETUP

<i>Tools</i>	<i>Materials/Parts</i>
General Mechanic's Automotive Tool Kit SC 5180 -90-CL-N26	Sealer (Item 29 or 30, Appendix D) Shims, SM-B-162197
Electronic Equipment Shelter Tool Kit TK-144/G	

---

*Replace. (figure 4-9)*

### NOTE

The shelter door has four hinge assemblies. This procedure is typical for all four. Do not remove more than one hinge at a time.

- (1) Remove five bolts (1 and 2), five self-locking nuts (3) and five flat washers (4) and take hinge assembly (5) and shim(s) (6) off door.
- (2) Coat both sides of shim(s) (6) with sealer.
- (3) Position hinge assembly (5) and shim(s) (6) on door and fasten with two long bolts (2), three short bolts (1), five flat washers (4) and five self-locking nuts (3).
- (4) Check latch torque. Latch torque should be 15 foot-pounds (max) without RFI/EMI gasket, or 30 foot-pounds (max) with RFI/EMI gasket. Add or subtract shims (6) to achieve proper latch torque. Latch torque may also be adjusted by varying number of latch keeper shims (para 3-15).
- (5) Lubricate as required (para 3-1).

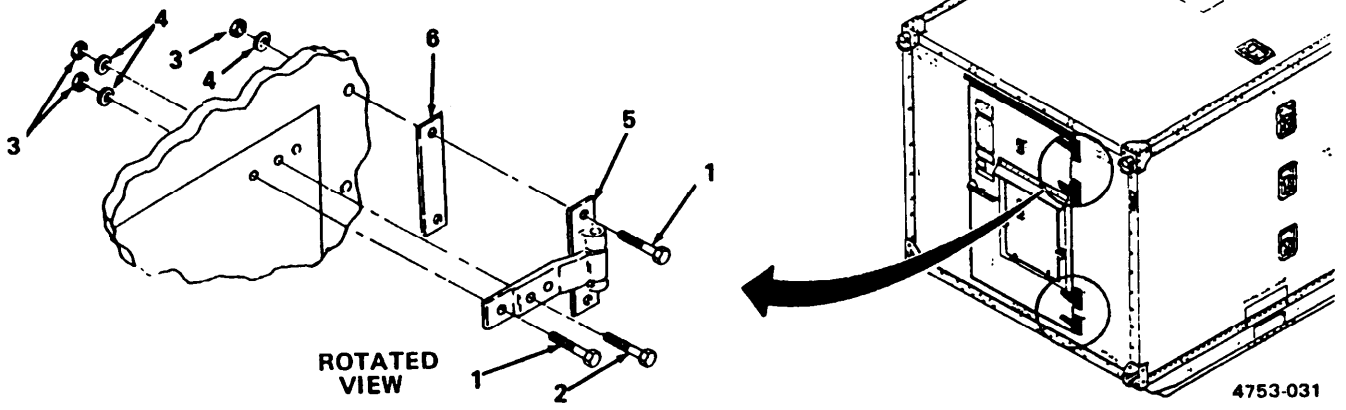

*Figure 4-9. Door Hinge Assembly Replacement.*

---

4-I8. **Door Skin.**

---

This task covers:      Repair

---

INITIAL SETUP

*Tools*

Electronic Equipment Shelter Tool Kit  
TK-144/G  
General Mechanic's Automotive Tool Kit  
SC 5180-90-CL-N26  
Blind Riveter

*Materials/Parts*

Adhesive Kit (Item 6, Appendix D)  
Rivets, Various  
Gloves (Item 12, Appendix D)  
Goggles (Item 38, Appendix D)

*General Safety Instructions*

**WARNING**

Adhesives contain toxic solvents. Avoid eye and skin contact and breathing of vapors. Use in a well-ventilated area. Use protective goggles and gloves. Use in accordance with manufacturer's instructions.

Drilling creates metal chips which may enter eyes and cause serious injury. Eye protection is required.

---

*Repair.*

**NOTE**

This procedure covers repair of door skin swelling and delamination. For patching of punctures, refer to paragraph 4-20.

The door skin is bonded to the underlayer with adhesive. The underlayer is solid wood in some areas and wood veneer over aluminum in other areas. Delamination occurs when unbroken skin pulls away from the underlayer.

- (1) Drill 1/4-inch deep holes through skin into underlayer, using a no. 20 drill bit. Space holes 1-1/2 inches apart along entire length of delaminated area.
- (2) Determine if subsurface is solid wood block or wood veneer over extruded aluminum.
- (3) Prepare adhesive by mixing base material and hardener in accordance with manufacturer's instructions. Use materials within one year from date of manufacture.
- (4) Apply adhesive between skin and underlayer.
- (5) Install screws in drilled holes where underlayer is solid wood block. Install rivets where underlayer is veneer over extruded aluminum. (Refer to paragraph 3-9.a for rivet installation instructions.)

---

**4-19. RFI/EMI Components.**

---

This task covers:      Replace

---

INITIAL SETUP

*Tools*

*Materials/Parts*

As required

RFI filter, PN SM-C-450478

---

*Replace.* RFI/EMI component replacement is limited to replacement of the RFI filter (para 4-15).



---

## 4-20. Wall, Floor and Ceiling Panels.

---

This task covers:      Repair

---

### INITIAL SETUP

#### *Tools*

Electronic Equipment Shelter Tool Kit  
TK-144/G  
General Mechanic's Automotive Tool Kit  
SC 5180-90-CL-N26  
Blind Riveter

#### *Materials/Parts (cont)*

Sealer (item 29 or 30, Appendix D)  
Cheesecloth (item 9 or 10, Appendix D)  
Gloves (Item 12, Appendix D)  
Goggles (Item 38, Appendix D)

#### *Materials/Parts*

Aluminum, Unpainted (Item 7 or 8, Appendix D)  
Sandpaper, Grit Nos. 40,60 and 80  
(Items 26, 27 and 28, Appendix D)  
Solvent (Item 37, Appendix D)  
Blind "Pop" Rivets, Various Sizes and  
Types  
Adhesive (Item 6, Appendix D)

#### *General Safety Instructions*

### **WARNING**

Adhesives and solvents are flammable and toxic. Keep away from heat and open flames. Avoid eye and skin contact and breathing of vapors. Use in a well-ventilated area. Use protective goggles and gloves. Use in accordance with manufacturer's instructions.

---

*Repair. (figure 4-10)*

### **CAUTION**

Paint strippers can contaminate panel core, adhesive and sealer. Do not use paint strippers to remove paint.

RFI/EMI shielded shelters should not be operated until a permanent patch has been applied.

### **NOTE**

The following procedures shall be used to repair small punctures that do not exceed 1/2-inch depth into foam core. All punctures must be patched immediately to prevent water intrusion and/or radiation leakage (shielded shelters). Dents without punctures do not require patching. However, if bare metal is exposed, touch up with paint (para 4-6).

Wall, ceiling and floor sandwich panels are alike in composition and construction. Repair procedures are the same for all sandwich panels.

- (1) Bend edges of puncture in below surface of unbroken face sheet. Do not allow broken edges to contact opposite face.
- (2) Remove loose fragments of foam and dust, using a vacuum, if necessary.

- (3) Cut a rectangular patch large enough to extend at least one inch beyond damaged area in all directions. Thoroughly degrease and clean patch within 72 hours before installation.
- (4) Center patch over damaged area, then lightly trace outline of patch on panel face.
- (5) Remove paint from panel face within marked outline by sanding or using a solvent. (Do not use paint stripper.) All traces of paint must be removed.

**WARNING**

Drilling creates metal chips which may enter eyes and cause serious injury. Eye protection is required.

- (6) Lay out rivet hole pattern around edge of patch. Rivet holes should be 1/4 to 1/2 inch in from edge of patch and one inch apart. Drill holes using a no. 11 or no. 12 drill.
- (7) Center patch over damaged area of panel.

**NOTE**

Drill two diagonally opposite corner holes first, then other two holes, then drill remaining holes.

- (8) Using drilled holes in patch as a guide, drill rivet holes in panel face sheet. Be careful not to drill through opposite face sheet. Insert a rivet in each hole as it is drilled to keep patch in place.
- (9) Remove patch and remove all burrs from drilled holes.
- (10) If puncture in panel is surrounded by extended cracks, drill a hole at the end of each crack, using a no. 30 drill, to keep crack from spreading.
- (11) Prepare adhesive by mixing base material and hardener in accordance with manufacturer's instructions. Use materials within one year from date of manufacture.
- (12) Prepare bonding surface of panel face sheet for bonding by sanding until oxide film is removed and bright surface is exposed.
- (13) Inject adhesive into puncture.
- (14) After adhesive has hardened, sand until adhesive is flush with surface of panel face.
- (15) Remove all contaminants (dirt, dust, oil, etc.) from bonding surfaces of patch and panel face, using a vacuum or clean, dry cloth. Wipe surfaces with clean cloth soaked in solvent and immediately wipe solvent from surface with clean cloth. Wear gloves to avoid contaminating surfaces with dirt, oil or fingerprints.
- (16) Apply thin, even layer of adhesive to bonding surfaces of panel face sheet and patch. Position patch in place with sheet fasteners.

**4-20. Wall, Floor and Ceiling Panels (cont).**

---

**NOTE**

When repairing an external face sheet, before installing rivets, inject sealer into drilled holes to prevent moisture from entering panel.

(17) Rivet patch to face sheet. (Refer to para 3-9.a for rivet installation instructions.)

(18) Wipe excess adhesive from surface of repaired area. Do not use solvent.

(19) Allow adhesive to dry.

(20) Coat edges of patch and rivet heads with sealer.

(21) Repaint as required (para 4-6).

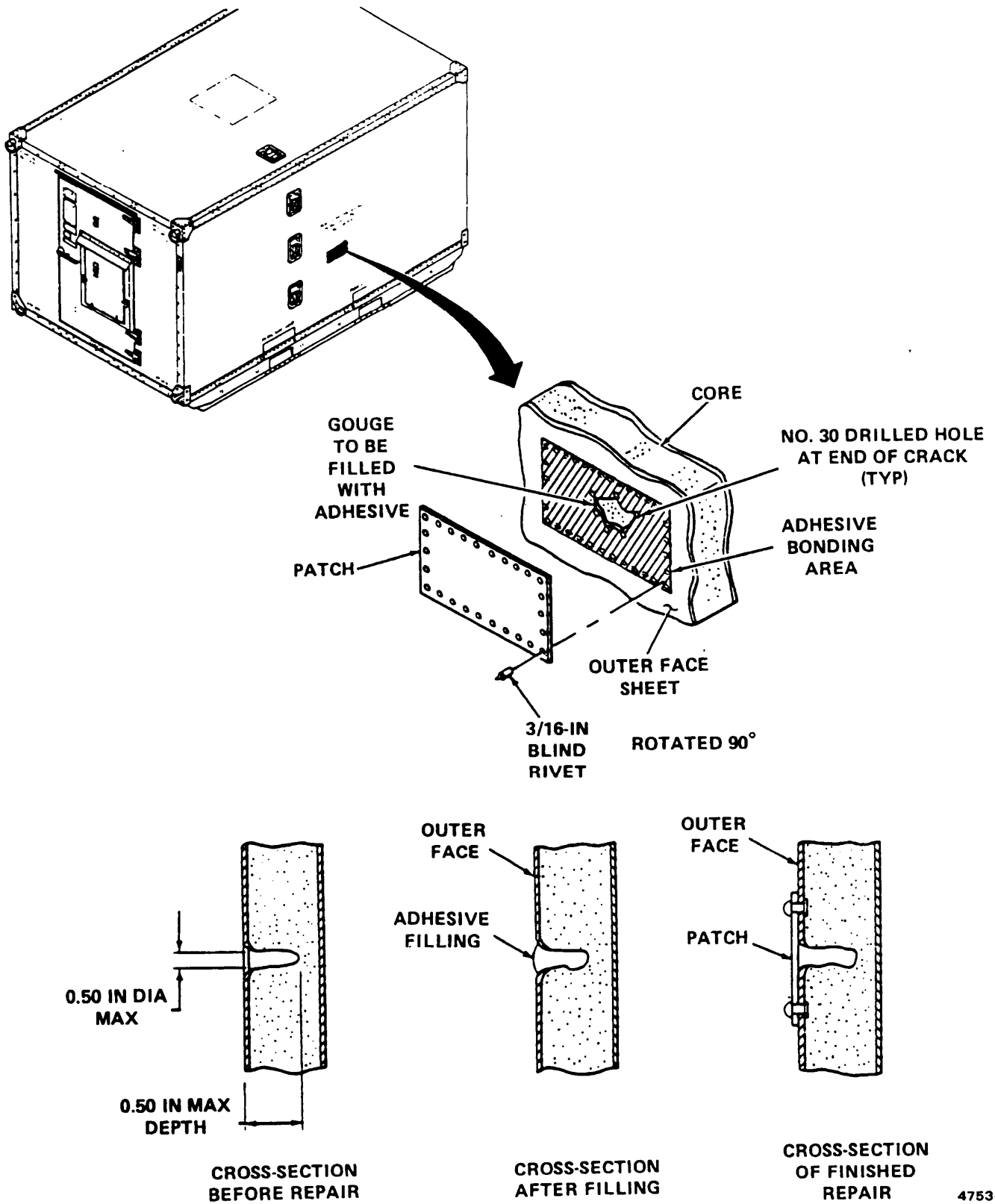

Figure 4-10. Panel Repair

**CHAPTER 5**

**GENERAL SUPPORT MAINTENANCE INSTRUCTIONS**

Subject	Section	Page
Repair Parts, Special Tools, TMDE and Support Equipment . . . . .	I	5-1
General Support Maintenance Procedures . . . . .	II	5-1

**Section I. REPAIR PARTS, SPECIAL TOOLS, TMDE AND SUPPORT EQUIPMENT**

Subject	Para	Page
Common Tools . . . . .	5-1	5-1
Special Tools, TMDE and Support Equipment . . . . .	5-2	5-1
Repair Parts . . . . .	5-3	5-1

5-1. **Common Tools.** A complete list of common tools and tool kits is given in Section III of Appendix B, Maintenance Allocation.

5-2. **Special Tools, TMDE and Support Equipment.** There are no special tools or equipment needed to maintain the shelters.

5-3. **Repair Parts.** Repair parts for general support maintenance of the shelters are listed and illustrated in TM 10-5411-206-24P.

**Section II. GENERAL SUPPORT MAINTENANCE PROCEDURES**

Subject	Para	Page
General . . . . .	5-4	5-1
Surface Preparation, Priming and Painting . . . . .	5-5	5-1
Door Assembly . . . . .	5-6	5-2
Towing Eye Assemblies . . . . .	5-7	5-4
Lifting Eye Assemblies . . . . .	5-8	5-6
RFI/EMI Shielding Gaskets . . . . .	5-9	5-8
Wall and Ceiling Panels . . . . .	5 10	5-10
Skid Assemblies and Mounting Brackets . . . . .	5-11	5-14

5-4. **General.** This section contains maintenance procedures which are the responsibility of general support maintenance, as authorized by the Maintenance Allocation Chart (appendix B). The general maintenance information given for unit level maintenance also applies to intermediate general support level maintenance. This information is contained in paragraph 3-8.

5-5. **Surface preparation, Priming and Painting.** All bare metal shall be painted to prevent corrosion. Touch up small dents and chips. Repaired sections of panels must be prepared with a corrosion protection primer before painting. Do not attempt to repaint large areas such as complete exterior interior or ceiling. Detailed priming and painting instructions can be found in TM 43-0139.

5-6. **Door Assembly.**

---

This task covers:      Replace

---

INITIAL SETUP

<i>Tools</i>	<i>Personnel Required</i>
General Mechanic's Automotive Tool Kit SC 5180 -90-CL-N26	Two
Electronic Equipment Shelter Tool Kit TK-144/G	Equipment Condition
<i>Materials/Parts</i>	Door brace assembly removed (para 3-11).
Sealer (Item 29 or 30, Appendix D)	

---

*Replace. (figure 5-1)*

**NOTE**

One person should support door assembly while second person removes and installs hardware.

- (1) Remove two bolts (1), two self-locking nuts (2) and two flat washers (3) securing each hinge (4) to shelter wall.
- (2) Push door assembly (5) out of shelter. Remove hinge shims (6).
- (3) Position shim(s) (6) against underside of each door hinge (4) and insert two bolts (1) through each hinge and shim(s).
- (4) Position door assembly (5) in shelter cutout and insert bolts (1) through mounting holes in shelter wall.
- (5) Install one flat washer (3) and one self-locking nut (2) on each bolt (1).
- (6) Check latch torque. Latch torque should be 15 foot-pounds (30 foot-pounds with RFI/EMI gasket). Add or subtract hinge shims (6) to achieve proper torque.

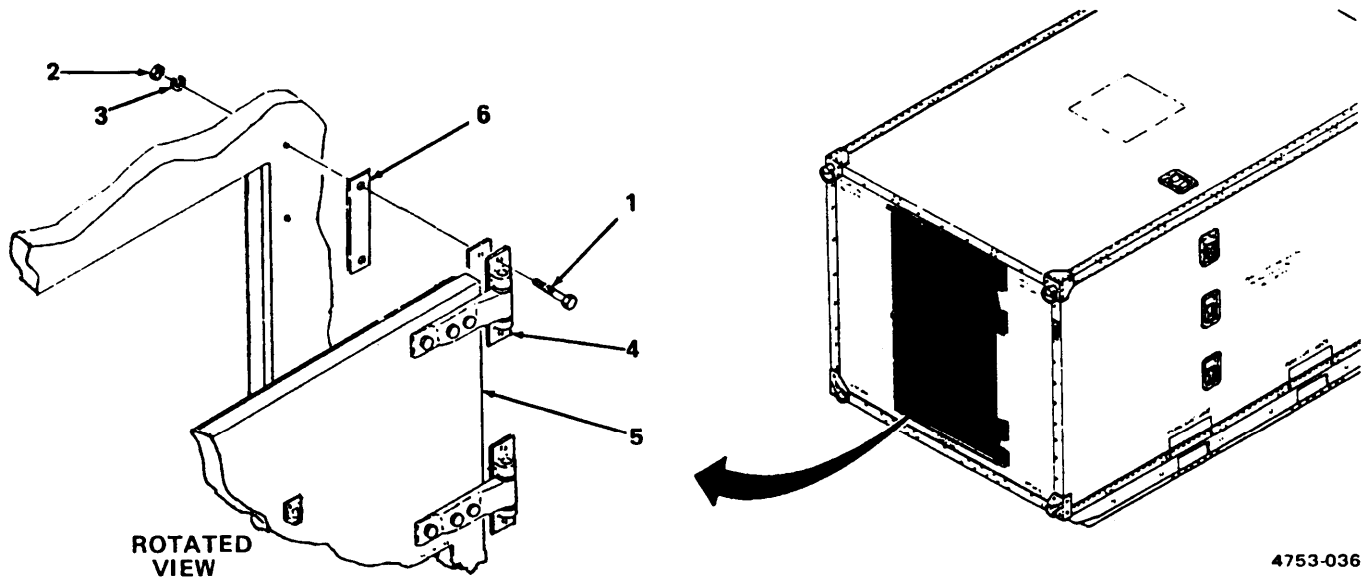

Figure 5-1. Door Assembly Replacement.

**NOTE**

**FOLLOW-ON MAINTENANCE:** Install door brace assembly (para 3-11).

---

## 5-7. Towing Eye Assemblies.

---

This task covers:      a. Remove              b. Disassemble              c. Assemble              d. Install

---

### INITIAL SETUP

#### *Tools*

General Mechanics Automotive Tool Kit  
SC 5180 -90-CL-N26  
Electronic Equipment Shelter Tool Kit TK-144/G

#### *Equipment Condition*

Skid assembly and mounting bracket removed  
(para 5-11).

#### *Materials/Parts*

Sealer (Item 29 or 30, Appendix D)

---

### NOTE

The shelter has one towing eye assembly at each bottom corner. This procedure is typical for all four.

a. *Remove. (figure 5-2)*

(1) Remove five socket head screws (1), two cap screws (2), two flat washers (3) and two lockwashers (4) and remove towing eye assembly (5 through 8).

(2) Remove and retain shims (9 and 10).

(3) Inspect condition of rivnuts (11) and replace if necessary (para 3-9.b).

b. *Disassemble (figure 5-2)*

Remove bolt (5) and self-locking nut (6) and take towing eye (7) off fitting (8).

c. *Assemble (figure 5-2)*

Position towing eye (7) on fitting (8) and fasten with bolt (5) and self-locking nut (6). Make sure bolt head is on top and nut on bottom, as shown in figure 5-2.

d. *Install. (figure 5-2)*

(1) Coat both sides of shims (9 and 10) and entire inside of fitting (8) with sealer.

(2) Position shims (9 and 10) against inside of towing eye fitting (8) so that mounting holes line up.

(3) Position towing eye assembly (5 through 8) on shelter corner so that eye (8) is on front or rear of shelter, as applicable.



- (4) Install five socket head screws (1) in side and bottom mounting locations.
- (5) Install two cap screws (2), two lockwashers (4) and two flat washers (3) in ring side mounting locations.
- (6) Apply a bead of sealer around edge of fitting (8).
- (7) Lubricate as required (para 3-1).

**NOTE**

**FOLLOW-ON MAINTENANCE:** Install skid assembly and mounting bracket (para 5-11).

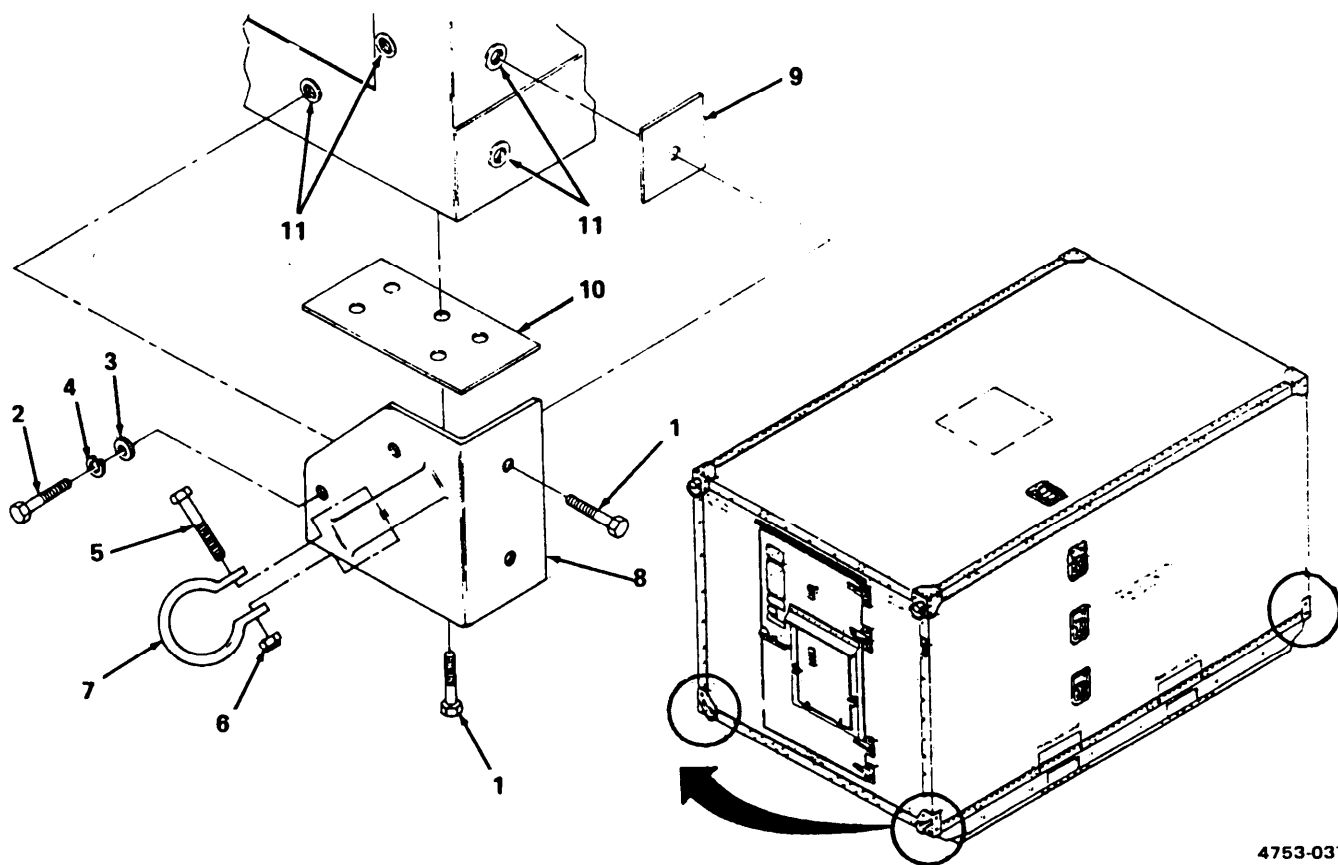

**Figure 5-2. Towing Eye Assembly Repair and Replacement.**

---

**5-8. Lifting Eye Assemblies.**

---

This task covers:      a. Remove      b. Disassemble      c. Assemble      d. Install

---

**INITIAL SETUP**

*Tools*

*Materials/Parts*

General Mechanic's Automotive Tool Kit  
SC 5180 -90-CL-N26

Sealer (Item 29 or 30, Appendix D)

Electronic Equipment Shelter Tool Kit TK-144/G

---

**NOTE**

The shelter has one lifting eye assembly at each top corner. This procedure is typical for all four lifting eye assemblies.

a. *Remove. (figure 5-3)*

- (1) Remove four cap screws (1), four flat washers (2), four lockwashers (3) and 11 socket head screws (4 and 5) and remove lifting eye assembly (6 through 10).
- (2) Remove and retain shims (11 and 12).
- (3) Inspect condition of rivnuts (13) and replace if necessary (para 3-9.b).

b. *Disassemble. (figure 5-3)*

- (1) Remove setscrew (6).
- (2) Unscrew and remove swivel pin (7) from ring assembly (8).
- (3) Pull ring assembly (8) out of casting (9) and remove spacer (10).

c. *Assemble. (figure 5-3)*

- (1) Position spacer (10) on casting (9) and insert threaded end of ring assembly (8).
- (2) Thread swivel pin (7) onto ring assembly (8) inside casting (9). Secure in place with setscrew (6).
- (3) Apply lubricant liberally to interior surfaces of swivel pin (7) and ring assembly (8).

d. *Install. (figure 5-3)*

- (1) Coat both sides of shims (11 and 12) and entire inside surface of casting (9) (except for area around swivel pin (7)) with sealer.
- (2) Position shims (11 and 12) against inside of casting (9) so that mounting holes line up.

- (3) Install four cap screws (1), four lock washers (3) and four flat washers (2) in ring side of lifting eye assembly.
- (4) Install nine long (1-1/8 in.) socket head screws (4) and two short (1 in.) socket head screws (5) in top and side of lifting eye assembly.
- (5) Apply a bead of sealer around edge of casting (9).
- (6) Lubricate as required (para 3-1 ).

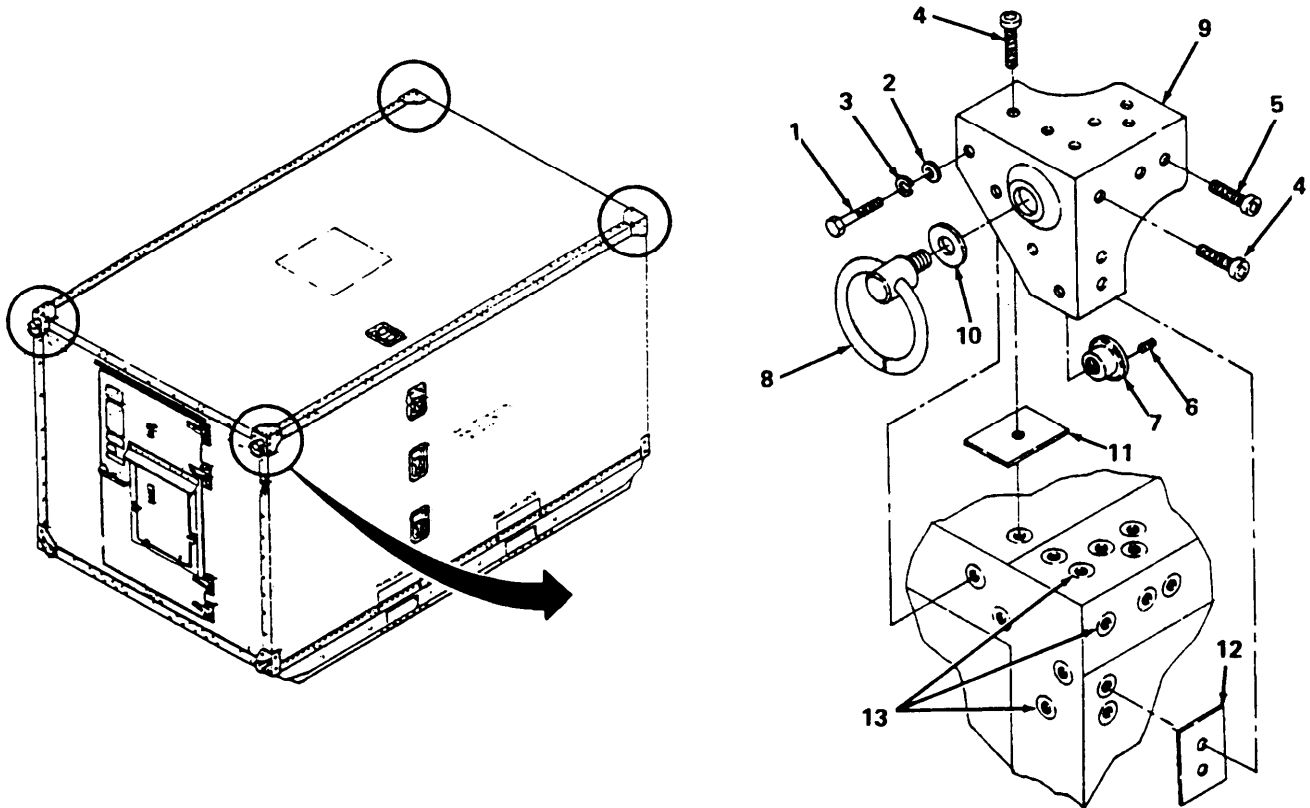

4753-038

Figure 5-3. Lifting Eye Assembly Repair and Replacement.

---

## 5-9. RFI/EMI Shielding Gaskets.

---

This task covers:      Replace

---

### INITIAL SETUP

#### *Tools*

General Mechanics Automotive Tool Kit  
SC 5180-90-CL-N26  
Electronic Equipment Shelter Tool Kit  
TK-144/G

#### *Materials/Parts*

Solvent (Item 37, Appendix D)  
Sealer (Item 29 or 30, Appendix D)  
Gloves (Item 12, Appendix D)  
Primer (Item 23, Appendix D)  
Gasket  
Goggles (Item 38, Appendix D)

---

#### *General Safety Instructions*

### **WARNING**

Solvents and sealers are flammable and toxic. Keep away from heat and open flames. Avoid skin and eye contact and breathing of vapors. Use in a well-ventilated area. Use protective goggles and gloves. Use in accordance with manufacturer's instructions.

*Replace. (figure 5-4)*

### **NOTE**

In shelters with RFI/EMI shielding, both outer door and inner door have shielding gaskets installed around inside edge. Replacement procedures are the same for both.

- (1) Remove gasket and scrape channel clean.
- (2) Remove residue of paint or sealer with solvent.
- (3) Cut new gasket to required length (complete length of channel) plus 2-1/2 inches.

### **NOTE**

Sealer must be applied between 30 minutes and eight hours after application of primer.

- (4) Apply primer, then sealer, evenly to sides and bottom of gasket channel to insure a continuous bond.
- (5) Immediately after applying sealer, press new gasket into place so that ends of gasket meet on hinged side of door.

### **NOTE**

Make gasket splice approximately midway up hinged side of door.

- (6) Pull back wire mesh shielding on one end of gasket, exposing sponge core.
- (7) Cut off 2-1/4 inches of exposed core. Do not cut wire mesh shielding.
- (8) Join ends of sponge core.
- (9) Roll wire mesh shielding over joined ends.

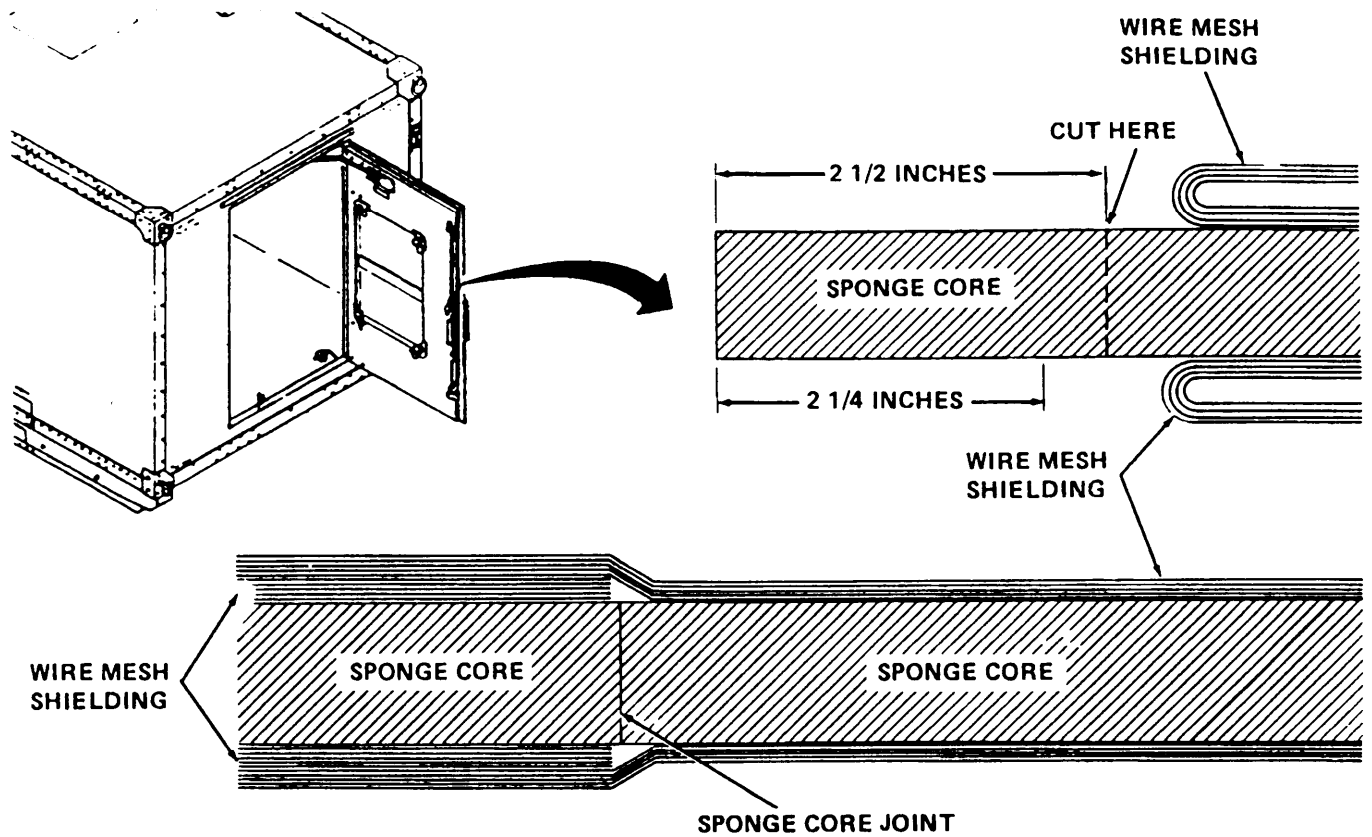

4753-039

Figure 5-4. RFI/EMI Shielding Gasket Replacement.

---

## 5-10. Wall and Ceiling Panels.

---

This task covers:      Repair

---

### INITIAL SETUP

#### *Tools*

General Mechanics Automotive Tool Kit  
SC 5180 -90-CL-N26  
Electronic Equipment Shelter Tool Kit TK-144/G  
Blind Riveter

#### *Materials/Parts*

Aluminum, Unpainted (Item 7 or 8, Appendix D)  
Sandpaper, Grit Nos. 40,60 and 80  
(Items 26,27 and 28, Appendix D)  
Solvent (Item 37, Appendix D)  
Insulation, Rigid Urethane Foam (Item 15,  
Appendix D)  
Blind "Pop" Rivets, Various Sizes and Types  
Adhesive (Items 2,3,4 or 5, Appendix D)  
Sealer (Item 29 or 30, Appendix D)

#### *Materials/Parts (cont)*

Cheesecloth (item 9 or 10, Appendix D)  
Gloves (Item 12, Appendix D)  
Goggles (Item 38, Appendix D)

#### *General Safety Instructions*

### **WARNING**

Adhesives and solvents are flammable and toxic. Keep away from heat and open flames. Avoid eye and skin contact and breathing of vapors. Use in a well-ventilated area. Use protective goggles and gloves. Use in accordance with manufacturer's instructions.

Drilling, sawing, and filing create metal chips which may enter eyes and cause serious injury. Eye protection is required.

---

*Repair. (figure 5-5)*

### **Caution**

Paint strippers can contaminate panel core, adhesive and sealer. Do not use paint strippers to remove paint.

RFI/EMI shielded shelters should not be operated until a permanent patch has been applied.

### **NOTE**

The following procedures shall be used to repair large punctures with foam core damage. All punctures must be patched immediately to prevent water intrusion and/or radiation leakage (shielded shelters). Dents without punctures do not require patching. However, if bare metal is exposed, touch up with paint (para 5-5).

Wall and ceiling sandwich panels are alike in composition and construction. Repair procedures are the same for both. If floor panel damage is too extensive to patch as described in paragraph 4-10, refer the shelter to higher maintenance level.

- (1) Cut a rectangular patch large enough to encompass damaged area on face sheet. Patch material must be same thickness as panel face sheet.
- (2) Using patch as a template, mark rectangle on face sheet covering damaged area. This will ensure that patch will fit snugly in face sheet cutout when patch is installed.
- (3) Cut out damaged face sheet within rectangle, using a router bit chucked in a 1/4-inch drill, a fine-tooth keyhole type hacksaw, or a circular saw.
- (4) Cut and remove core material to opposite face sheet using a knife.
- (5) If both sides of panel are damaged, repeat steps (1) through (3) for opposite side of panel. Second cutout should be identical to and directly opposite first cutout.
- (6) File cutout edges smooth, using fine cut, half round file, or rotary file chucked in 1/4-inch drill.
- (7) Remove loose fragments of foam, dust and metal. Use a vacuum, if necessary.
- (8) Remove paint from panel face around each cutout for a distance of 1-1/2 inches (up to two inches for very large cutouts). Paint may be sanded off or removed with solvent. All traces of paint must be removed.
- (9) If only one face sheet has been cut out, clean bonding (interior) surface of opposite face sheet until smooth.

#### NOTE

If cutouts have been made in both sides of panel, steps (10) through (15), (17), (18) and (21) through (25) apply to both face sheets.

- (10) Cut a doubler for patch. Make doubler one inch larger all around that cutout (up to two inches for very large cutouts).
- (11) Lay out rivet hole pattern in patch and doubler. Rivet holes should be 1/4 to 1/2 inch from edge and one inch apart. (Hole spacing may be increased to two inches when distance between two corner holes exceeds 20 inches.) Drill holes using a no. 11 or no. 12 drill (no. 12 or no. 30 for large patches). Remove all metal chips and burrs from drilled holes.
- (12) Center patch on doubler and drill rivet holes in doubler, using drilled holes in patch as a template. Secure patch to doubler by temporarily inserting rivets.
- (13) Center doubler (with patch temporarily fastened) over cutout in panel, making sure patch fits snugly and flush in cutout.

#### NOTE

Drill two diagonally opposite corner holes first, then other two corner holes, then drill remaining holes.

**5-10. Wall and Ceiling Panels (cont).**

---

- (14) Drill rivet holes in panel face sheet, using holes drilled in doubler as a template. Use drill and pin as a stop by placing drill inside pin and setting drill in chuck so that 7/16 to 9/16 inch of drill is exposed when pin is against chuck jaws. Temporarily insert a rivet in each hole as it is drilled to keep patch and doubler from moving.
- (15) Remove doubler and patch. Remove all metal chips and remove burrs from drilled holes.

**CAUTION**

When machining foam core, be careful not to crush foam, since this results in water absorption. Do not use a plane to machine foam.

- (16) Cut section of new foam core material to fit snugly in core cavity. Core material must be flush with inside of both panel faces when installed. Use a single piece of foam.
- (17) Prepare bonding surfaces of face sheet, patch and doubler for bonding by sanding until oxide film is removed and bright surface is exposed.
- (18) Wipe surfaces with clean cloth soaked in solvent. Immediately wipe solvent from surface with clean cloth. Wear gloves to avoid contaminating surfaces with dirt, oil or fingerprints.
- (19) Prepare adhesive by mixing base material and hardener in accordance with manufacturer's instructions. Use materials within one year from date of manufacture.
- (20) Apply adhesive liberally to all surfaces of new core material and cavity and position core material in cavity.
- (21) Apply a thin, even layer of adhesive to bonding surfaces of face sheet, patch and doubler. Position patch in place on doubler with sheet fasteners.

**NOTE**

When repairing an external face sheet, before installing rivets, inject sealer into drilled holes to prevent moisture from entering panels.

- (22) Rivet patch to doubler and doubler to face sheet. (Refer to paragraph 3-9.a for rivet installation instructions.)
- (23) Wipe excess adhesive from outer surfaces of repaired area. Do not use solvent to remove adhesive.
- (24) Allow adhesive to dry.
- (25) Coat edges of doubler and rivet heads with sealer,
- (26) Touch up with paint as required (para 5-5).



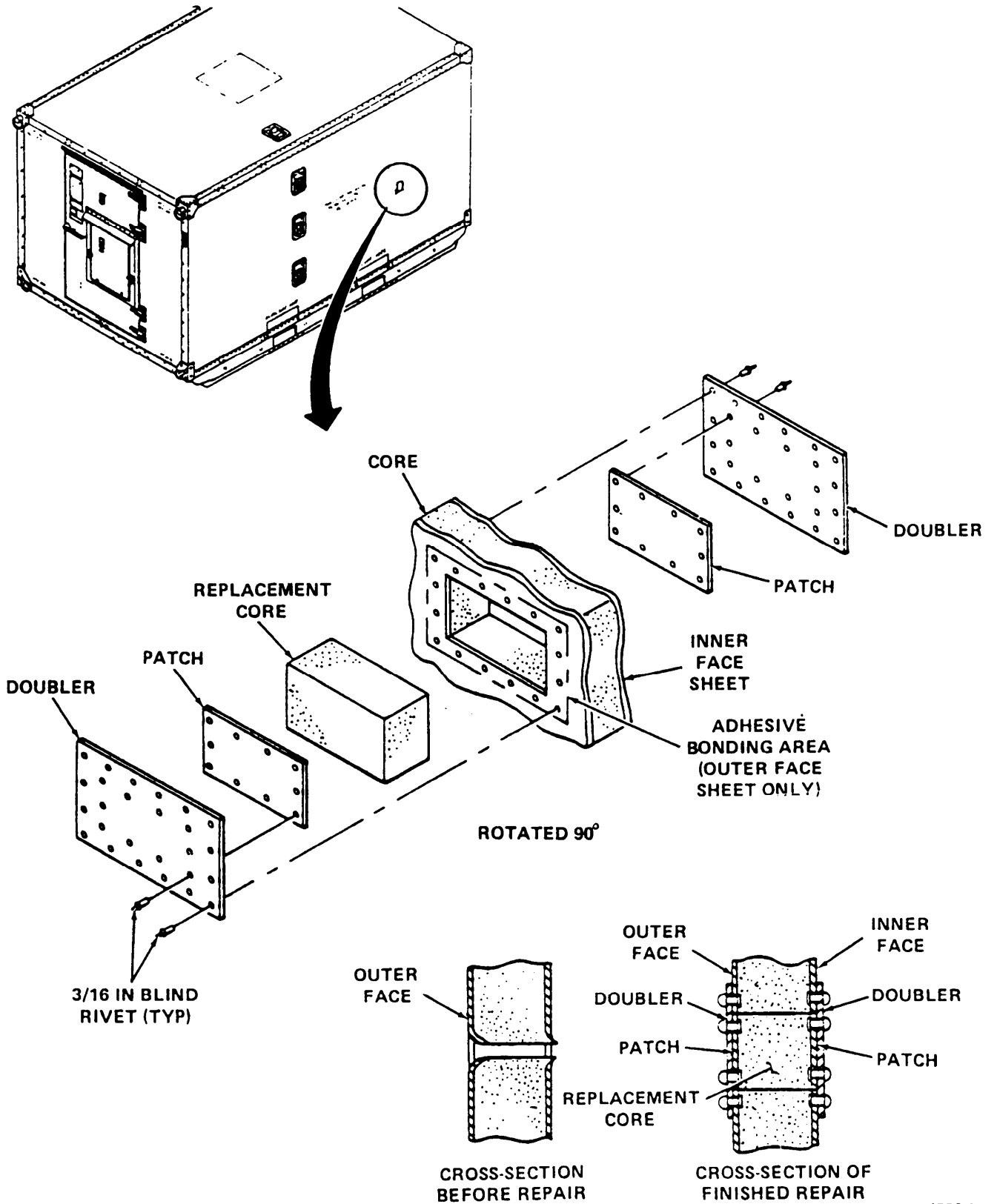

4753-040

Figure 5-5. Panel Repair.

---

5-11. **Skid Assemblies and Mounting Brackets.**

---

This task covers:     Replace

---

INITIAL SETUP

<i>Tools</i>	<i>Materials/Parts</i>
General Mechanic's Automotive Tool Kit SC 5180-90-CL-N26	Sealer (Item 29 or 30, Appendix D) Rivnuts, Various
Electronic Equipment Shelter Tool Kit TK-144/G	<i>Personnel Required</i>
	Four

---

*Replace. (figure 5-6)*

**NOTE**

The shelter has three skid assemblies and three mounting brackets. The procedure is the same for all three, except where noted.

- (1) Lift shelter and load it onto blocks high enough to allow ample clearance between skid assemblies and floor for hardware removal and installation. (Refer to paragraph 3-5 for lifting and loading instructions.)
- (2) Remove six hex head bolts (1), six hex nuts (2) and twelve flat washers (3) and remove skid assembly (4) from mounting bracket (5).
- (3) Remove eight socket head screws (6), 48 hex head screws (7 and 8), four flat washers (9) and four lockwashers (10) and remove mounting bracket (5) from shelter floor.

**NOTE**

Shims (12 and 13) are only used with center mounted skid mounting bracket.

- (4) Remove shims (11 through 13). Record number of shims (11) removed.
- (5) Inspect rivnuts and replace if necessary (para 3-9.b).
- (6) Position shims (11 ) on ends of mounting bracket (5). Use same number of shims removed (step (4)).

**NOTE**

Shims (12 and 13) are only used with center mounted skid mounting bracket.

- (7) Position one shim (12) on each end of mounting bracket (5) on top of shims (11). Place shim (13) on mounting bracket. Make sure all mounting holes line up.

- (8) Coat exposed side of shim (13) (the side that will mate with shelter floor) with sealer.
- (9) Position mounting bracket (5), together with all shims, on shelter bottom.
- (10) Install four hex head screws (7), with one lockwasher (10) and one flat washer (9) each, in end pair of mounting holes at each end of mounting bracket (5). Install eight socket head screws (6) and 44 hex head screws (8) in remaining mounting holes.
- (11) If required, replace shelter on ground (para 3-5).

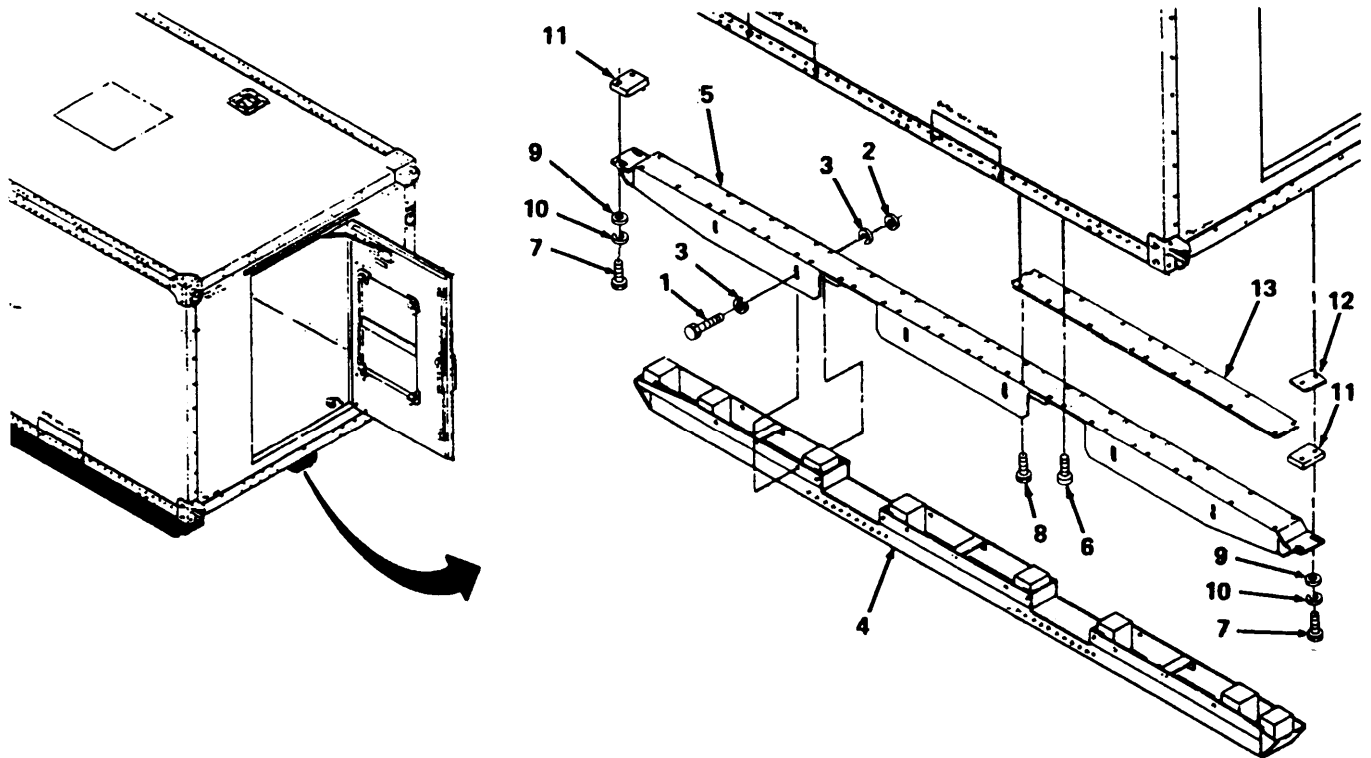

4753-041

Figure 5-6. Skid Assembly and Mounting Bracket Replacement.

## APPENDIX A

### REFERENCES

A-1. **Scope.** This appendix lists all forms, military specifications, technical manuals and miscellaneous publications referenced in this manual.

#### A-2. **Forms and Records.**

Recommended Changes to Publications and Blank Forms . . . . .	DA Form 2028
Recommended Changes to Equipment Technical Publications . . . . .	DA Form 2028-2
Equipment Inspection and Maintenance Worksheet . . . . .	DA Form 2404
Report of item Discrepancy . . . . .	SF364
Product Quality Deficiency Report . . . . .	SF368

#### A-3. **Department of the Army Pamphlets.**

The Army Maintenance Management System (TAMMS) . . . . .	DA Pam 738-750
--	----------------

#### A-4. **Military Specifications.**

Cloth, Cheesecloth, Cotton, Bleached and Unbleached . . . . .	CCC-C-440
Coating, Epoxy, Polyamide . . . . .	MIL-C-22750
Coating, Aliphatic, Polyurethane, Chemical Agent Resistant . . . . .	MIL-C-46168
Lubricant, Solid Film, Air Drying, Corrosion Inhibiting . . . . .	MIL-L-23398
Marking of Electronic Items . . . . .	MIL-M-13231
Sealing Compound, Temperature-Resistant, Integral Fuel Tank and Fuel Cell Cavities, High Adhesion Sealant . . . . .	MIL-S-8802
Silicone Compound, NATO Code Number S-736 . . . . .	MIL-S-22473
Aluminum Alloy, Bar, Rod, Shapes, Tube and wire, Extruded . . . . .	QQ-A-200/8
Aluminum Alloy 6061, Plate and Sheet . . . . .	QQ-A-250/11
Thinner, Synthetic Resin, Enamels . . . . .	TT-T-306
Toluene, Technical Grade . . . . .	TT-T-548

#### A-5. **Technical Manuals and Bulletins.**

Loading of S-280( )/G Shelters in Container ANSI/ISO Type 1AA. . . . .	TB 11-5400-200-14
Repair Parts and Special Tools List for Shelter, Electrical Equipment S-280 B/G and S-280 B/G (Shielded) . . . . .	TM 10-5411-206-24P
Painting instructions for Field Use . . . . .	TM 43-0139
Destruction of Army Materiel to Prevent Enemy Use . . . . .	TM 750-244-3

## APPENDIX B

### MAINTENANCE ALLOCATION CHART

#### Section I INTRODUCTION

##### B-1. General.

- a. This section provides a general explanation of all maintenance and repair functions authorized at various maintenance categories.
- b. The Maintenance Allocation Chart (MAC) in section II designates overall authority and responsibility for the performance of maintenance functions on the identified end item or component. The application of the maintenance functions to the end item or component will be consistent with the capacities and capabilities of the designated maintenance categories.
- c. Section III lists the tools and test equipment (both special tools and common tool sets) required for each maintenance function as referenced from section II.
- d. Section IV contains supplemental instructions and explanatory notes for a particular maintenance function.

**B-2. Maintenance Functions.** Maintenance functions will be limited to and defined as follows: (except for ammunition MAC).

- a. *Inspect.* To determine the serviceability of an item by comparing its physical, mechanical, and/or electrical characteristics with established standards through examination (e.g. by sight, sound, or feel).
- b. *Test.* To verify serviceability by measuring the mechanical, pneumatic, hydraulic, or electrical characteristics of an item and comparing those characteristics with prescribed standards.
- c. *Service.* Operations required periodically to keep an item in proper operating condition, i.e., to clean (includes decontaminate, when required), to preserve, to drain, to paint, or to replenish fuel, lubricants, chemical fluids, or gases.
- d. *Adjust.* To maintain or regulate, within prescribed limits, by bringing into proper or exact position or by setting the operating characteristics to specified parameters.
- e. *Aline.* To adjust specified variable elements of an item to bring about optimum or desired performance.
- f. *Calibrate.* To determine and cause corrections or adjustments to be adjusted on instruments or test, measuring, and diagnostic equipment used in precision measurement. Consists of comparisons of two instruments, one of which is a certified standard of known accuracy, to detect and adjust any discrepancy in the accuracy of the instrument being compared.
- g. *Remove/Install.* To remove and install the same item when required to perform service or other maintenance functions. Install may be the act of emplacing, seating, or fixing into position a spare, repair part, or module (component or assembly) in a manner to allow the proper functioning of an equipment or system.

**B-2. Maintenance Functions (cont).**

h. *Replace*. To remove an unserviceable item and install a serviceable counterpart in its place. "Replace" is authorized by the MAC and is shown as the 3rd position code of the SMR code.

i. *Repair*. The application of maintenance services, including fault location/troubleshooting, removal/installation, and disassembly/assembly procedures, and maintenance actions to identify troubles and restore serviceability to an item by correcting specific damage, fault, malfunction, or failure in a part, subassembly, module (component or assembly), end item, or system.

j. *Overhaul*. That maintenance effort (service/action) prescribed to restore an item to a completely serviceable/operational condition as required by maintenance standards in appropriate technical publications (i.e., DMWR). Overhaul is normally the highest degree of maintenance performed by the Army. Overhaul does not normally return an item to like new condition.

k. *Rebuild*. Consists of those services/actions necessary for the restoration of unserviceable equipment to a like new condition in accordance with original manufacturing standards. Rebuild is the highest degree of materiel maintenance applied to Army equipment. The rebuild operation includes the act of returning to zero those age measurements (hours/miles, etc.) considered in classifying Army equipment/components.

**B-3. Explanation of Columns in the MAC, Section II**

a. *Column 1, Group Number*. Column 1 lists functional group code numbers, the purpose of which is to identify maintenance significant components, assemblies, subassemblies, and modules with the next higher assembly. End item group number shall be "00".

b. *Column 2, Component/Assembly*. Column 2 contains the names of components, assemblies, subassemblies, and modules for which maintenance is authorized.

c. *Column 3, Maintenance Function*. Column 3 lists the functions to be performed on the item listed in Column 2. (For detailed explanation of these functions, see paragraph B-2).

d. *Column 4, Maintenance Category*. Column 4 specifies, by the listing of work time figure in the appropriate subcolumn(s), the category of maintenance authorized to perform that maintenance function at the indicated category of maintenance. If the number or complexity of the tasks within the listed maintenance function vary at different maintenance categories, appropriate work time figures will be shown for each category. The work time figure represents the average time required to restore an item (assembly, subassembly, component, module, end item, or system) to a serviceable condition under typical field operating conditions. This time includes preparation time (including any necessary disassembly/assembly time), troubleshooting/fault location time, and quality assurance/quality control time in addition to the time required to perform the specific tasks identified for the maintenance functions authorized in the maintenance application chart. The symbol designations for the various maintenance categories are as follows:

Code	Explanation
C .....	Operator or crew
0 .....	Unit maintenance
F .....	Direct Support Maintenance

Code	Explanation
H .....	General Support Maintenance
D .....	Depot Maintenance

*e. Column 5. Tools and Equipment.* Column 5 specifies, by code, those common tool sets (not individual tools) and special tools, TMDE, and support equipment required to perform the designated function.

*f. Column 6. Remarks.* This column shall, when applicable, contain a letter code, in alphabetic order which shall be keyed to the remarks contained in Section VI.

**B-4. Explanation of Columns in Tool and Test Equipment Requirements, Section II.**

*a. Column 1. Reference Code.* The tool and test equipment reference code correlates with a code used in the MAC, Section II, Column 5.

*b. Column 2. Maintenance Category.* The lowest level of maintenance authorized to use the tool or test equipment.

*c. Column 3. Nomenclature.* Name or identification of the tool or test equipment.

*d. Column 4. National Stock Number.* The National stock number of the tool or test equipment.

*e. Column 5. Tool Number.* The manufacturer's part number.

**B-5. Explanation of Columns in Remarks, Section IV.**

*a. Column 1. Reference Code.* The code recorded in column 6, Section II.

*b. Column 2. Remarks.* This column lists information pertinent to the maintenance function being performed as indicated in the MAC, Section II.

**Section II. MAINTENANCE ALLOCATION CHART FOR SHELTER, ELECTRICAL EQUIPMENT S-280B/G AND S-280B/G (SHIELDED)**

(1) GROUP NUMBER	(2) COMPONENT/ ASSEMBLY	(3) MAINTENANCE FUNCTION	(4) Maintenance LEVEL					(5) TOOLS AND EQPT.	(6) REMARKS
			UNIT		DIRECT SUPPORT	GENERAL SUPPOR	DEPOT		
			C	O	F	H	D		
00	SHELTER, ELEC- TRICAL EQUIPMENT S-280B/G AND S-280B/G SHIELDED	Inspect Repair Repair	0.2		5.0				A
01	DOOR BRACE ASSEMBLY	Inspect Service Repair Replace	0.2	0.2 0.5 1.0				1 1	B
02	DOOR ASSEMBLY	Inspect Service Repair Repair Replace	0.2	0.2 0.5	4.0	2.0		1 1, 2, 3 1, 2	B C D,E
0201	EMERGENCY EXIT PANEL ASSEMBLY	Inspect Service Repair Repair Replace	0.2	0.2 0.5 1.0	2.0			1 1, 2, 3 1	B C D,E
0202	DOOR HANDLES, LOCKS/LATCHES	Inspect Service Repair Replace	0.2	0.2 1.0 1.5				1 1	B
0203	AIR INLET FILTER	Inspect Replace	0.2	0.5				1, 3	
03	TOWING BRACKET ASSEMBLIES	Inspect Service Repair Replace	0.2	0.5		0.5 4.0		1, 2 1, 2	B
04	LIFTING BRACKET ASSEMBLIES	Inspect Service Repair Replace	0.2	0.5		1.5 2.0		1, 2 1, 2	B



(1) GROUP NUMBER	(2) COMPONENT/ ASSEMBLY	(3) MAINTENANCE FUNCTION	(4) MAINTENANCE LEVEL					(5) TOOLS AND EQPT.	(6) REMARKS
			UNIT		DIRECT SUPPORT	GENERAL SUPPORT	DEPOT		
			c	o	F	H	D		
05	STEPS, HAND HOLDS, DRAIN PLUG	Inspect Service Replace	0.2	0.2 1.5				B	
06	RFI/EMI COMPONENTS	Inspect Replace Replace Replace	0.2	0.5	1.0	3.0	1, 2 1, 2	F E G	
07	PANEL WALLS, FLOORS,CEILINGS	Inspect Repair Repair Repair	0.2	0.5	2.5	8.0	1,2,3 1,2,3	C D H	
08	SKID ASSEMBLY AND MOUNTING BRACKET	Inspect Replace	0.2			3.0	1,2		

**Section III. TOOL AND TEST EQUIPMENT REQUIREMENTS FOR SHELTER,  
ELECTRICAL EQUIPMENT S-280B/G AND S-280B/G (SHIELDED)**

TOOL OR TEST EQUIPMENT REF CODE	MAINTENANCE CATEGORY	NOMENCLATURE	NATIONAL/NATO STOCK NUMBER	TOOL NUMBER
1	O,F,H	TOOL KIT, GENERAL MECHANICS AUTOMOTIVE SC 5180-90-CL-N26	5180-00-177-7033	
2	F,H	TOOL KIT, ELECTRONIC EQUIPMENT SHELTER TK-144/G	5180-00-973-4369	
3	O,F,H	RIVETER, BLIND HAND	5120-00-017-2849	

**Section IV. REMARKS**

REFERENCE CODE	REMARKS
A	Replace drip molding, plates, hinges, door stop angle, floor tread
B	Lubricate, touchup paint
C	Temporary repair of skin damage
D	Permanent repair of minor skin damage
E	Replace intake louver, RFI filter, drip cap, knobs, weather gaskets, hinges
F	Replace RFI/EMI washer
G	Replace RFI/EMI gasket
H	Repair of major skin damage with foam core damage

**APPENDIX C**

**COMPONENTS OF END ITEM AND BASIC ISSUE ITEMS LISTS**

**Section I INTRODUCTION**

**C-1. Scope.**

This appendix lists components of end item and basic issue items for the S-280B/G and S-280B/G Shielded shelters to help you inventory items required for safe and efficient operation.

**C-2. General.**

The Components of End Item and Basic Issue Items Lists are divided into the following sections:

*a. Section II. Components of End.* This listing is for information purposes only, and is not authority to requisition replacements. These items are part of the end item, but are removed and separately packaged for transportation or shipment. As part of the end item, these items must be with the end item whenever it is issued or transferred between property accounts. Illustrations are furnished to assist you in identifying the items.

*b. Section III. Basic Issue Item.* These are the minimum essential items required to place the shelter in operation, to operate it, and to perform emergency repairs. Although shipped separately packaged, BII must be with the shelter during operation and whenever it is transferred between property accounts. The illustrations will assist you with hard-to-identify items. This manual is your authority to request/requisition replacement BII, based on TOE/MTOE authorization of the end item.

**C-3. Explanation of Columns.**

The following provides an explanation of columns found in the tabular listings:

*a. Column (1) - Illustration Number (Illus Number).* This column indicates the number of the illustration in which the item is shown.

*b. Column (2) - National Stock Number.* Indicates the National stock number assigned to the item and will be used for requisitioning purposes.

*c. Column (3) - Description.* Indicates the Federal item name and, if required, a minimum description to identify and locate the item. The last line for each item indicates the FSCM (in parentheses) followed by the part number. If item needed differs for different models of this equipment, the model is shown under the "Usable On" heading in this column. These codes are identified as follows:

Code	Used On
A	Model S-280B/G
B	Model S-280B/G Shielded

*d. Column (4) - Unit of Measure (U/M).* Indicates the measure used in performing the actual operational/maintenance function. This measure is expressed by a two-character alphabetical abbreviation (e.g., ea, in, pr).

*e. Column (5) - Quantity required (Qty rqr).* Indicates the quantity of the item authorized to be used with/on the equipment.

Section II. COMPONENTS OF END ITEM

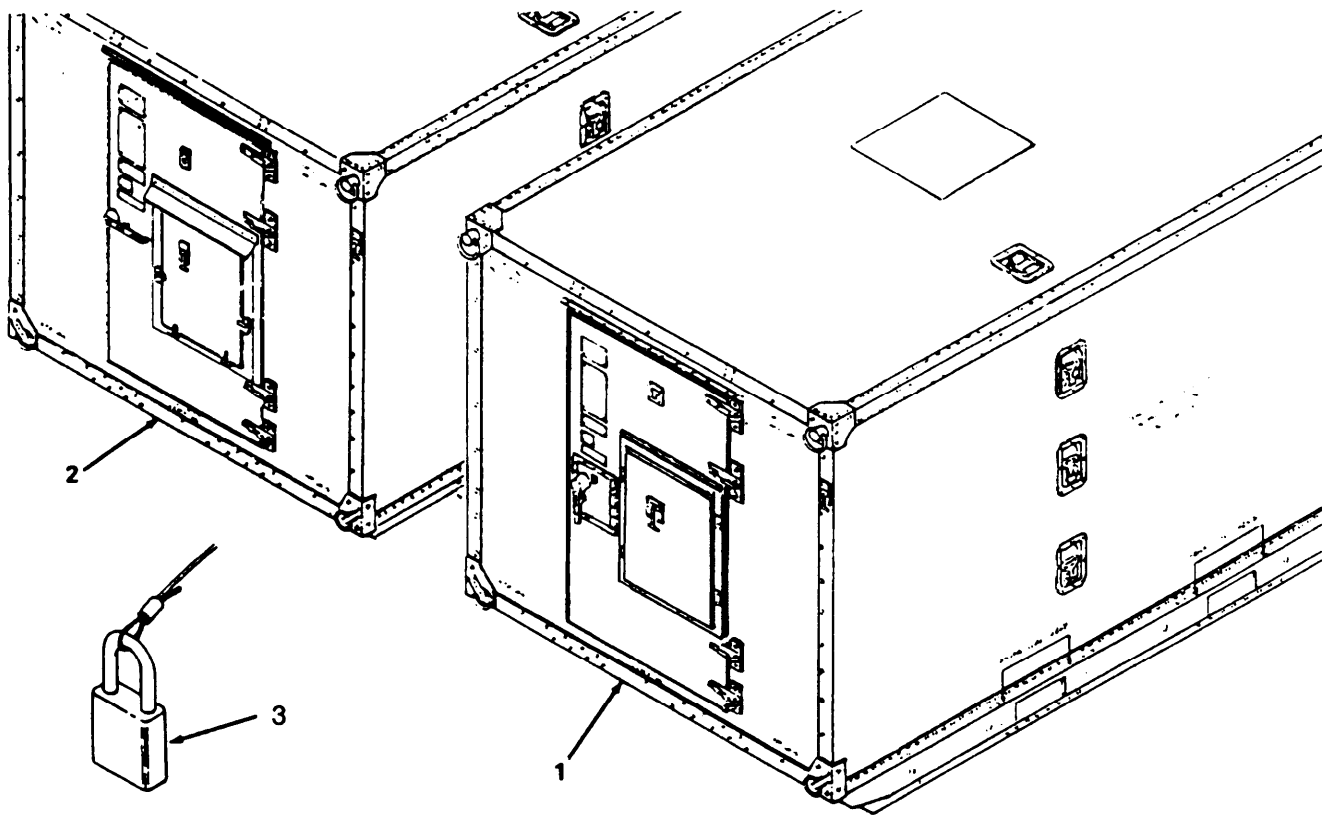

4753-043

(1) Illus Number	(2) National Stock Number	(3) Description FSCM and Part Number	Usable On Code	(4) U/M	(5) Qty Rqr
1	5410-00-117-2868	SHELTER, ELECTRICAL EQUIPMENT S-280B/G (80063) SM-D-200131	A	EA	1
2	5410 -00-001-4093	SHELTER, ELECTRICAL EQUIPMENT S-280B/G (SHIELDED) (80063) SM-D-200131	B	EA	1
3	5340-01-239-8705	PADLOCK AND KEY (80063) SC-C-595537	A,B	EA	1

**Section III. BASIC ISSUE ITEMS**

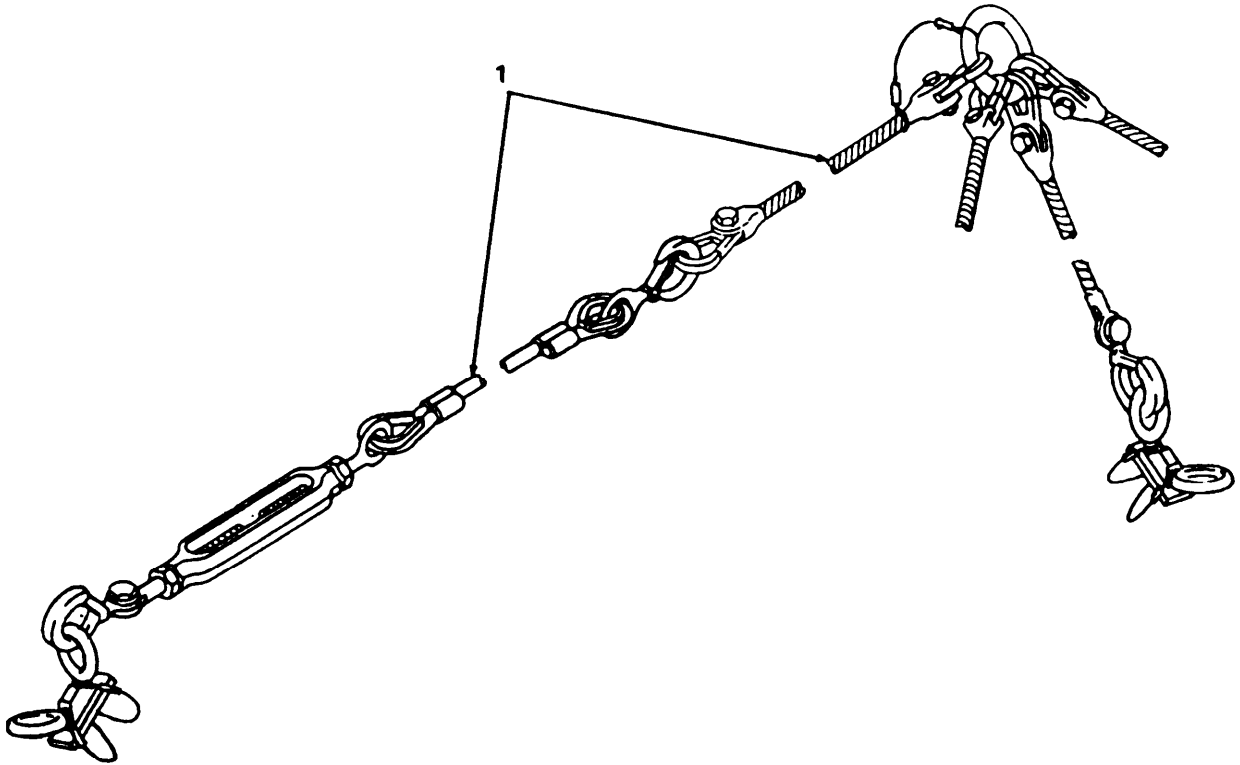

4753-044

(1) Illus Number	(2) National Stock Number	(3) Description FSCM and Part Number	(4) Usable On Code U/M	(5) Qty Rqr
1		HOLD DOWN ASSEMBLY (80063) SC-D-36423	EA	1

**APPENDIX D**

**EXPENDABLE/DURABLE SUPPLIES AND MATERIALS LIST**

**Section I. INTRODUCTION**

**D-1. Scope.**

This appendix lists expendable supplies and materials you will need to operate and maintain the shelters. This listing is for information purposes only and is not authority to requisition the listed items. These items are authorized to you by CTA 50-970, Expendable Items (Except Medical, Class V, Repair Parts, and Heraldic Items), or CTA 8-100, Army Medical Department Expendable/Durable Items.

**D-2. Explanation of Columns.**

- a. Column (1) – Item Number. This number is assigned to the entry in the listing.
- b. Column (2)–level. This column identifies the lowest level of maintenance that requires the listed item.

(enter as applicable)

- C - Operator
- O - Unit Maintenance
- F - Direct Support Maintenance
- H - General Support Maintenance

c. Column (3) - National Stock Number. This the National stock number assigned to the item; use it to request or requisition the item.

d. Column (4) - Description. Indicates the Federal item name, and, if required, a description to identify the item. The last line for each item indicates the Federal Supply Code for Manufacturer (FSCM) in parentheses followed by the part number.

e. Column (5) - Unit of Measure (U/M). Indicates the measure used in performing the actual maintenance function. This measure is expressed by a two-character alphabetical abbreviation (e.g., ea, in, pr). If the unit of measure differs from the unit of issue, requisition the lowest unit of issue that will satisfy your requirements.

**Section II. EXPENDABLE/DURABLE SUPPLIES AND MATERIALS**

(1) Item Number	(2) Level	(3) National stock number	(4) Description	(5) U/M
1	F	8040-00-016-8662	Adhesive, epoxy, hysol	bx
2	O	8040-00-952-3520	Adhesive, silicone rubber, 6 oz. tube	oz
3	O	8040-00-851-0211	Adhesive, silicone rubber, 5 oz. tube (black)	oz
4	O	8040-00-865-8991	Adhesive, silicone rubber, 12 oz. can (black)	oz

EXPENDABLE/DURABLE SUPPLIES AND MATERIALS (cont)

(1) Item Number	(2) Level	(3) National stock number	(4) Description	(5) U/M
5	O	8040-00-142-9823	Adhesive, silicone rubber, 12 oz. can (aluminum)	oz
6	F	8040-01-035-7848	Adhesive kit, two part, metal to metal	
7	F		Aluminum sheet, .040 in. thick QQ-A-250/11 6061-T6	
8	F		Aluminum sheet, .040 in. thick QQ-A-200/8 5052-H34	
9	O	8305-00-267-3015	Cloth, cheesecloth	yd
10	O	8305-00-205-3496	Cloth, cheesecloth, CCC-440, Type II, Class 2	yd
11	O		Conductive compound (80063) SM-D-555530-25 or SC-D-200140-12	
12	O	8415-00-634-4658	Gloves, leather	pr
13	F		Gasket (80063) SM-D-450461-4, SM-D-450462-7 or -8, and SM-B-555582	
14	F		Grease, Iubriplate (130-AA) (80063) SM-D-649953-5	
15	H		Insulation, closed cell rigid urethane foam, MIL-C-83400 or polystyrene foam, MIL-S-55286	
16	O	9150-00-823-7860	Lubricant, MIL-C-83300	
17	O	9550-00-402-4478	Lubricant, MIL-L-23398	
18	O		Lubricant, silicone, MIL-S-8660	
19	F	7220-00-254-4240	Matting, rubber floor, 1/8 in. thick	
20	F	7220-00-965-4699	Matting, tubber floor, 3/16 in. thick	
21	O		Paint, lusterless green enamel, MIL-E-46061 (S-280A/G) or Paint, lusterless green, no 383, polyurethane, MIL-C-46168 (S-280B/G)	gl
22	O		Paint, polyamide epoxy, MIL-C-22750	gl

## EXPENDABLE/DURABLE SUPPLIES AND MATERIALS (cont)

(1) Item Number	(2) Level	(3) National stock number	(4) Description	(5) U/M
23	F	8030-00-845-4304	Primer for silastic TRV891, 1 pint can black	pt
24	F	9320-00-202-4008	Rubber, solid sheet, 1/8 in. thick	
25	F	9320-00-621-5409	Rubber, solid sheet, 1/8 in. thick	
26	O	5350-00-192-9318	Sandpaper, grit no. 40	
27	O	5350-00-192-5046	Sandpaper, grit no. 60	
28	O	5350-00-192-5047	Sandpaper, grit no. 80	
29	O	8030-00-753-5005	Sealing compound, 6 oz, MIL-S-8802	oz
30	O	8030-00-081-2333	Sealing compound, MIL-S-22473	
31	H	8030-00-275-8110	Sealing compound, 2-part kit, resin with catalyst	
32	O	5970-00-543-1005	Tape, electrically conductive	
33	O	7510-00-266-6712	Tape, masking, 1 in. wide	
34	O	7510-00-266-6714	Tape, masking, 1 1/2 in. wide	
35	O	7510-00-266-6712	Tape, pressure-sensitive adhesive, 2 in. wide	
36	F	8010-00-160-5794	Thinner, synthetic resin enamel, IT-T-306	
37	O	6610-00-579-8431	Toluene, technical grade solvent, TT-T-548	
38	O	4240-00-052-3776	Goggles, Industrial	pr



## INDEX

Subject	Paragraph
<b>A</b>	
Abbreviations . . . . .	1-6
Adjustments, initial . . . . .	2-4
Administrative Storage . . . . .	3-24
Air Inlet Filters	
Replacement . . . . .	3-16
Service . . . . .	3-16
Assembly and Preparation for Use . . . . .	2-3
<b>B</b>	
Basic Issue Items . . . . .	C-1
Blind Rivets, Installation and Removal . . . . .	3-9
<b>C</b>	
Ceiling Panel, Repair . . . . .	4-20, 5-10
Characteristics, Capabilities and Features . . . . .	1-7
Component Location and Description . . . . .	1-8
Components of End Item . . . . .	C-1
<b>D</b>	
D-Ring Assemblies	
Replacement . . . . .	3-18
Service . . . . .	3-18
Data, Equipment . . . . .	1-10
Data Plates, Replacement . . . . .	4-8
Destruction of Army Material to Prevent Enemy Use . . . . .	1-4
Differences Between Models . . . . .	1-9
Direct Support Maintenance Procedures . . . . .	4-5
Door Assembly	
Repair, Direct Support . . . . .	4-11
Replacement, General Support . . . . .	5-6
Service and Repair, Unit . . . . .	3-12
Door Brace Assembly	
Repair . . . . .	3-11
Replacement . . . . .	3-11
Service . . . . .	3-11
Door Knob Assembly, Replacement . . . . .	4-16
Door Latch Assembly	
Repair . . . . .	3-15
Replacement . . . . .	3-15
Door Skin, Repair . . . . .	4-18
Door Stop Angle, Replacement . . . . .	4-9
Drain Plug, Replacement . . . . .	3-19

**D (cont)**

Drip Cap, Replacement . . . . . 4-13  
Drip Mold, Replacement . . . . . 4-7

**E**

Emergency Exit  
  Latch Replacement . . . . . 4-14  
  Repair . . . . . 4-14  
  Strike Replacement . . . . . 4-14  
  Stud Plate Assembly Relacement . . . . . 4-14  
Emergency Exit Panel Assembly  
  Repair . . . . . 3-13  
  Replacement . . . . . 3-13  
  Service . . . . . 3-13  
Emergency Procedures . . . . . 2-9  
EMI Washer, Replacement . . . . . 3-19  
Expendable/Durable Supplies and Materials . . . . . D-1

**F**

Filter, RFI, Replacement . . . . . 4-15  
Filters, Air Inlet  
  Replacement . . . . . 3-16  
  Service . . . . . 3-16  
Floor Panel Repair . . . . . 4-20  
Floor Tread Replacement . . . . . 4-10

**G**

Gaskets, Weather Replacement . . . . . 4-12  
General Support Maintenance Procedures . . . . . 5-4

**H**

Hand Holds  
  Replacement . . . . . 3-18  
  Service . . . . . 3-18

**I**

Initial Adjustment . . . . . 2-4  
Instruction Plates . . . . . 2-7  
Intake Louver Assembly, Replacement . . . . . 4-15

**J,K**

INDEX (cont)

Subject Paragraph

L

Latch Assembly Door  
     Repair . . . . . 3-15  
     Replacement . . . . . 3-15  
 Lifting Eye Assembly  
     Repair . . . . . 5-8  
     Replacement . . . . . 5-8  
 Lifting Shelter . . . . . 3-5  
 Loading Shelter Into ANSI/ISO Container . . . . . 3-22  
 Loading Shelter Onto Truck . . . . . 3-5  
 Lubrication Instructions . . . . . 3-1

M

Maintenance Allocation Chart . . . . . B-4  
 Maintenance Forms and Records . . . . . 1-2  
 Maintenance Procedures  
     Direct Supportl . . . . . 4-5  
     General Support . . . . . 5-4  
     Unit . . . . . 3-8  
 Marking, Shelter . . . . . 1-11  
 Movement, Preparation For . . . . . 2-6

N

O

Operating Procedures . . . . . 2-5  
 Operation in Unusual Weather . . . . . 2-8

P

Painting, Touchup . . . . . 3-10  
 Panel Assembly, Emergency Exit  
     Repair . . . . . 3-13  
     Replacement . . . . . 3-13  
     Service . . . . . 3-13  
 Panel Repair  
     Permanent Patching . . . . . 4-20, 5-10  
     Temporary (Tape). . . . . 3-9  
 Plates, Data, Replacement . . . . . 4-8  
 Plates, instruction . . . . . 2-7  
 Preparation for Movement . . . . . 2-6  
 Preparation for Shipment and Storage . . . . . 1-5  
 Preventive Maintenance Checks and Services, Operator . . . . . 2-1

INDEX (cont)

Subject	Paragraph
<b>Q</b>	
<b>R</b>	
Recessed Step Pan Assembly	
Replacement . . . . .	3-17
Service . . . . .	3-17
References . . . . .	A-1
Repair Parts . . . . .	3-3, 4-3 , 5-3
Repair Procedures, General . . . . .	3-9
Reporting Equipment Improvement Recommendations (EIR) . . . . .	1-3
RFI Filter Replacement . . . . .	4-15
RFI/EMI Components, Replacement . . . . .	3-20, 4-19, 5-9
RFI/EMI Shielding Gasket Replacement . . . . .	5-9
Rivet Installation and Removal . . . . .	3-9
Rivnut Installation and Removal . . . . .	3-9
<b>S</b>	
Safety, Care and Handling . . . . .	1-12
Scope . . . . .	1-1
Securing Shelter on Truck . . . . .	3-5
Service Upon Receipt . . . . .	3-5
Shielding Gasket, RFI/EMI Replacement . . . . .	5-9
Shipment, Preparation For . . . . .	1-5
Site Requirements . . . . .	3-6
Skid Assembly, Replacement . . . . .	5-11
Skid Mounting Bracket, Replacement . . . . .	5-11
Skin, Door, Repair . . . . .	4-18
Special Tools . . . . .	3-2, 4-2, 5-2
Steps, Roof Access	
Replacement . . . . .	3-17
Service . . . . .	3-17
Storage, Administrative . . . . .	3-24
Storage, Preparation For . . . . .	1-5
Storage Requirements, General . . . . .	3-23
Surface Preparation, Priming and Painting . . . . .	4-6, 5-5
<b>T</b>	
T-Latches and Holders, Replacement . . . . .	3-14
Towing Eye Assemblies	
Repair . . . . .	5-7
Replacement . . . . .	5-7
Tread, Floor, Replacement . . . . .	4-10

**INDEX (cont)**

Subject Paragraph

**T (cont)**

Troubleshooting	
Direct Support .....	4-4
Unit .....	3-7

**U**

Unit Maintenance Procedures .....	3-8
-----------------------------------	-----

**V**

**W**

Washer, EMI, Replacement .....	3-19
--------------------------------	------

**X, Y, Z**

By Order of the Secretary of the Army:

**GORDON R. SULLIVAN**  
*General, United States Army*  
*Chief of Staff*

Official:



**MILTON H. HAMILTON**  
*Administrative Assistant to the*  
*Secretary of the Army*  
05411

**DISTRIBUTION:**

To be distributed in accordance with DA Form 12-25-E, block no. 6169, requirements for TM 10-5411-206-14.



THEN... JOT DOWN THE DOPE ABOUT IT ON THIS FORM. CAREFULLY TEAR IT OUT. FOLD IT AND DROP IT IN THE MAIL!

SOMETHING WRONG WITH THIS PUBLICATION?

FROM (PRINT YOUR UNIT'S COMPLETE ADDRESS)  
**PFC JOHN DOE**  
**COA, 3d ENGINEER BN**  
**FT. LEONARDWOOD, MD 63108**  
 DATE SENT

PUBLICATION NUMBER TM 10-5411-206-14	PUBLICATION DATE 30 Sept 1993	PUBLICATION TITLE SHELTER ELECTRICAL EQUIP.
---	----------------------------------	--

BE EXACT. PIN-POINT WHERE IT IS				IN THIS SPACE TELL WHAT IS WRONG AND WHAT SHOULD BE DONE ABOUT IT:
PAGE NO	PARA-GRAPH	FIGURE NO	TABLE NO	
6	2-1 a			In line 6 of paragraph 2-1a the manual states the engine has <u>6</u> cylinders. The engine on my set only has <u>4</u> cylinders. Change the manual to show <u>4</u> cylinders.
B1		4-3		Callout 16 on figure 4-3 is pointing at a <u>bolt</u> . In key to figure 4-3, item 16 is called a <u>skin</u> - Please correct one or the other.
125	line 20			I ordered a gasket, item 19 on figure B-16 by NSN 2 910-00-762-3001. I got a gasket but it doesn't fit. Supply says I got what I ordered, so the NSN is wrong. Please give me a good NSN

PRINTED NAME, GRADE OR TITLE, AND TELEPHONE NUMBER <b>JOHN DOE, PFC (268) 317-7111</b>	SIGN HERE <b>JOHN DOE</b>
---	------------------------------

TEAR ALONG PERFORATED LINE

RECOMMENDED CHANGES TO EQUIPMENT TECHNICAL PUBLICATIONS



# SOMETHING WRONG WITH THIS PUBLICATION?

THEN... JOT DOWN THE DOPE ABOUT IT ON THIS FORM. CAREFULLY TEAR IT OUT. FOLD IT AND DROP IT IN THE MAIL!

FROM (PRINT YOUR UNIT'S COMPLETE ADDRESS)

DATE SENT

PUBLICATION NUMBER

TM 10-5411-206-14

PUBLICATION DATE

30 Sept 1993

PUBLICATION TITLE

SHELTER ELECTRICAL EQUIP.

BE EXACT PIN-POINT WHERE IT IS

PAGE NO

PARA-GRAPH

FIGURE NO

TABLE NO

IN THIS SPACE TELL WHAT IS WRONG AND WHAT SHOULD BE DONE ABOUT IT:

TEAR ALONG PERFORATED LINE

PRINTED NAME, GRADE OR TITLE, AND TELEPHONE NUMBER

SIGN HERE

DA FORM 2028-2  
1 JUL 79

PREVIOUS EDITIONS ARE OBSOLETE.  
DRSTS-M Overprint 2, 1 Nov 80.

P.S.--IF YOUR OUTFIT WANTS TO KNOW ABOUT YOUR RECOMMENDATION MAKE A CARBON COPY OF THIS AND GIVE IT TO YOUR HEADQUARTERS.



1 Nov 80

FILL IN YOUR  
UNITS ADDRESS



FOLD BACK

DEPARTMENT OF THE ARMY

---

---

OFFICIAL BUSINESS

COMMANDER  
U.S. ARMY AVIATION AND TROOP COMMAND  
ATTN: AMSAT-I-MP  
4300 GOODFELLOW BOULEVARD  
ST. LOUIS, MO 63120-1798

TEAR ALONG PERFORATED LINE

**Linear Measure**

1 centimeter = 10 millimeters = .39 inch  
 1 decimeter = 10 centimeters = 3.94 inches  
 1 meter = 10 decimeters = 39.37 inches  
 1 dekameter = 10 meters = 32.8 feet  
 1 hectometer = 10 dekameters = 328.08 feet  
 1 kilometer = 10 hectometers = 3,280.8 feet

**Weights**

1 centigram = 10 milligrams = .15 grain  
 1 decigram = 10 centigrams = 1.54 grains  
 1 gram = 10 decigrams = .035 ounce  
 1 dekagram = 10 grams = .35 ounce  
 1 hectogram = 10 dekagrams = 3.52 ounces  
 1 kilogram = 10 hectograms = 2.2 pounds  
 1 quintal = 100 kilograms = 220.46 pounds  
 1 metric ton = 10 quintals = 1.1 short tons

**Liquid Measure**

1 centiliter = 10 milliliters = .34 fl. ounce  
 1 deciliter = 10 centiliters = 3.38 fl. ounces  
 1 liter = 10 deciliters = 33.81 fl. ounces  
 1 dekaliter = 10 liters = 2.64 gallons  
 1 hectoliter = 10 dekaliters = 26.42 gallons  
 1 kiloliter = 10 hectoliters = 264.18 gallons

**Square Measure**

1 sq. centimeter = 100 sq. millimeters = .155 sq. inch  
 1 sq. decimeter = 100 sq. centimeters = 15.5 sq. inches  
 1 sq. meter (centare) = 100 sq. decimeters = 10.76 sq. feet  
 1 sq. dekameter (are) = 100 sq. meters = 1,076.4 sq. feet  
 1 sq. hectometer (hectare) = 100 sq. dekameters = 2.47 acres  
 1 sq. kilometer = 100 sq. hectometers = .386 sq. mile

**Cubic Measure**

1 cu. centimeter = 1000 cu. millimeters = .06 cu. inch  
 1 cu. decimeter = 1000 cu. centimeters = 61.02 cu. inches  
 1 cu. meter = 1000 cu. decimeters = 35.31 cu. feet

## Approximate Conversion Factors

To change	To	Multiply by	To change	To	Multiply by
inches	centimeters	2.540	ounce-inches	newton-meters	.007062
feet	meters	.305	centimeters	inches	.394
yards	meters	.914	meters	feet	3.280
miles	kilometers	1.609	meters	yards	1.094
square inches	square centimeters	6.451	kilometers	miles	.621
square feet	square meters	.093	square centimeters	square inches	.155
square yards	square meters	.836	square meters	square feet	10.764
square miles	square kilometers	2.590	square meters	square yards	1.196
acres	square hectometers	.405	square kilometers	square miles	.386
cubic feet	cubic meters	.028	square hectometers	acres	2.471
cubic yards	cubic meters	.765	cubic meters	cubic feet	35.315
fluid ounces	milliliters	29.573	cubic meters	cubic yards	1.308
pints	liters	.473	milliliters	fluid ounces	.034
quarts	liters	.946	liters	pints	2.113
gallons	liters	3.785	liters	quarts	1.057
ounces	grams	28.349	liters	gallons	.264
pounds	kilograms	.454	grams	ounces	.035
short tons	metric tons	.907	kilograms	pounds	2.205
pound-feet	newton-meters	1.356	metric tons	short tons	1.102
pound-inches	newton-meters	.11296			

## Temperature (Exact)

°F	Fahrenheit temperature	5/9 (after subtracting 32)	Celsius temperature	°C
----	------------------------	----------------------------	---------------------	----

**PIN: 071888-000**